



# Lightning Analysis: creating geo-frameworks

University of Utah  
03 March 2017

H. Roice Nelson, Jr.  
Dynamic Measurement LLC



# Picking up from talk at “U” on 16 Oct 2014



## Possible Thesis/Dissertation Topics



1. Electrical characteristics of Elm and Oak trees, including root systems and preferential soil chemistries.
2. Statistical Analysis of lightning strike clusters related to topography, vegetation, infrastructure, and geology.
3. Modeling telluric currents as a means to predict lightning clusters.
4. Modeling lightning clusters as a means to predict telluric currents.
5. Relationship between lightning clusters and high altitude lightning events like blue sprites and elves.
6. Using lightning clusters as a basis for time-lapse electromagnetic measurements.
7. Lightning analysis of Iron County, UT relating strike attributes to known iron reserves and micro-earthquakes.\*
8. Lightning analysis of Prince of Wales Island, Alaska to extend maps of vein-dyke rare earth deposits.\*
9. Lightning analysis of Cortez Hills, NV (116°-117°W , 40°-41°N) to calibrate known gold mines and trends.\*
10. Lightning analysis of San Bernardino County, CA to map the extent of the Mountain Pass Rare Earth deposit.\*
11. Lightning analysis of the Mississippian Limestone hydrocarbon play in OK and KS.\*
12. Quantitative correlation of South Texas lightning density with known oil and gas fields.
13. Correlation of lightning density with mapped gas hydrates offshore North Carolina.\*
14. Correlation of lightning density with known oil and gas fields in Southern Louisiana.\*
15. Mapping top geopressure and correlating lightning clusters with shallow depth to top geopressure in TX & LA.\*
16. Correlate lightning attributes and density with gravity and magnetic and electrical and seismic data.
17. Lightning analysis Yellowstone National Park to correlate with known geothermal deposits.

\*Requires licensing of lightning data.



# Presentation Outline



Milam County Texas apparent-resistivity Volume

- 1. Lightning Occurs Everywhere**
- 2. Lightning Database Analytics**
- 3. Rock Property & Attribute Maps & Volumes**
- 4. Lightning Analysis & Attributes**
- 5. Texas, New York, Louisiana, & Arizona Examples**

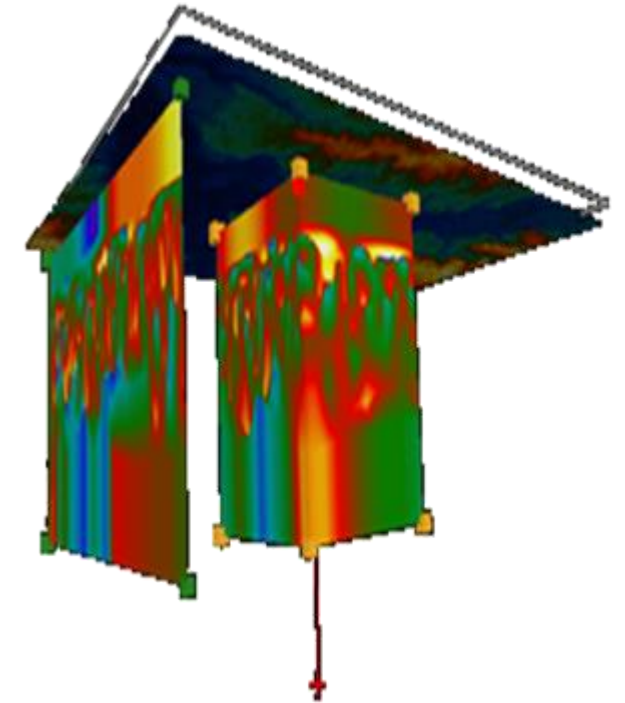





# DML Started with 2 Questions:



1. Can lightning hit twice at the same place?
2. Does this mean there is oil on my property?



Strikes from 1 storm (colors Peak Current ) 27 Sep 2011, Hockley Dome, Harris County, TX





# The Answer to Both Questions is Yes!



The answer to the first question is “yes,” lightning strikes cluster and the clusters are consistent over time.

The answer the second question is “there is oil here,” as shown by the tanks now at the location of the lightning strikes raising the question.





# 1. Lightning Occurs Everywhere

5+ years of data in GLD-360 database



Dr. Jim Siebert  
Chief Meteorologist Fox  
News Houston and  
Dynamic Measurement

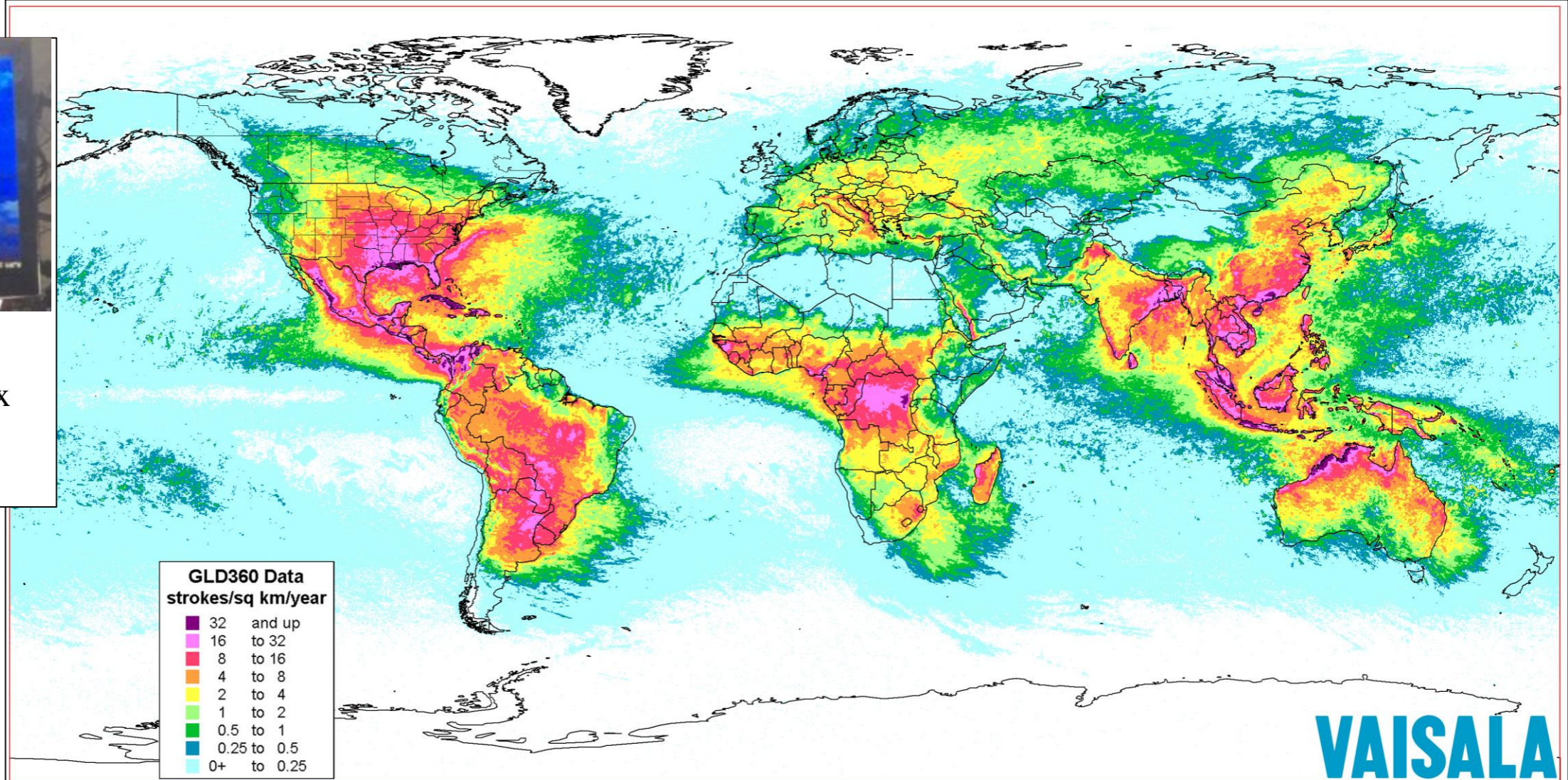

Stroke Density Map - 20 km grid

May 6, 2011 - May 5, 2015



GLD360 data



# The U.S. & Canada have the best lightning data

18+ Years of Data in the NLDN & CLDN Database



## NLDN (National Lightning Detection Network)

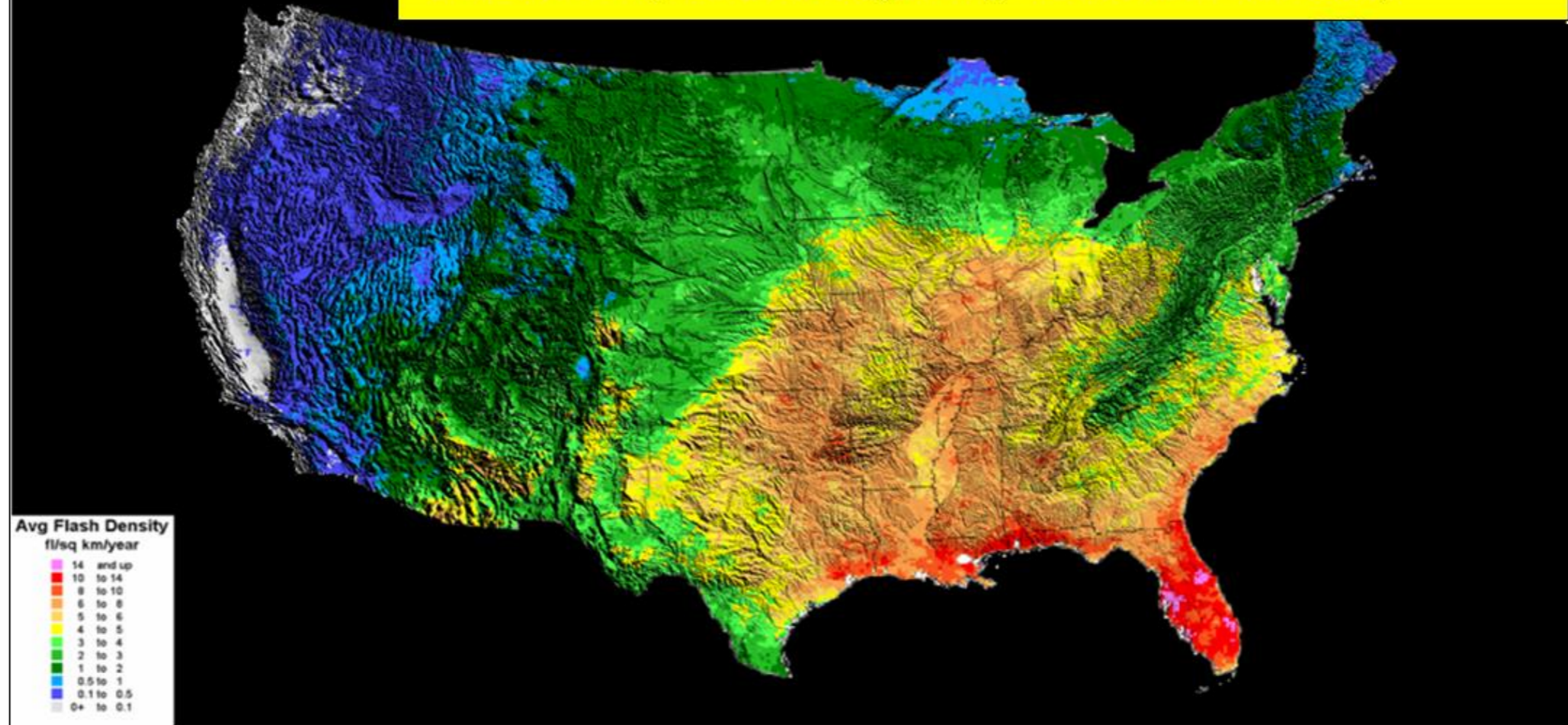

**Originally Collected for Insurance, Meteorology, and Safety Reasons**



# Sensors Measure Direction to Strike & Lightning Attributes

Strikes Triangulated & Measurements Reconciled

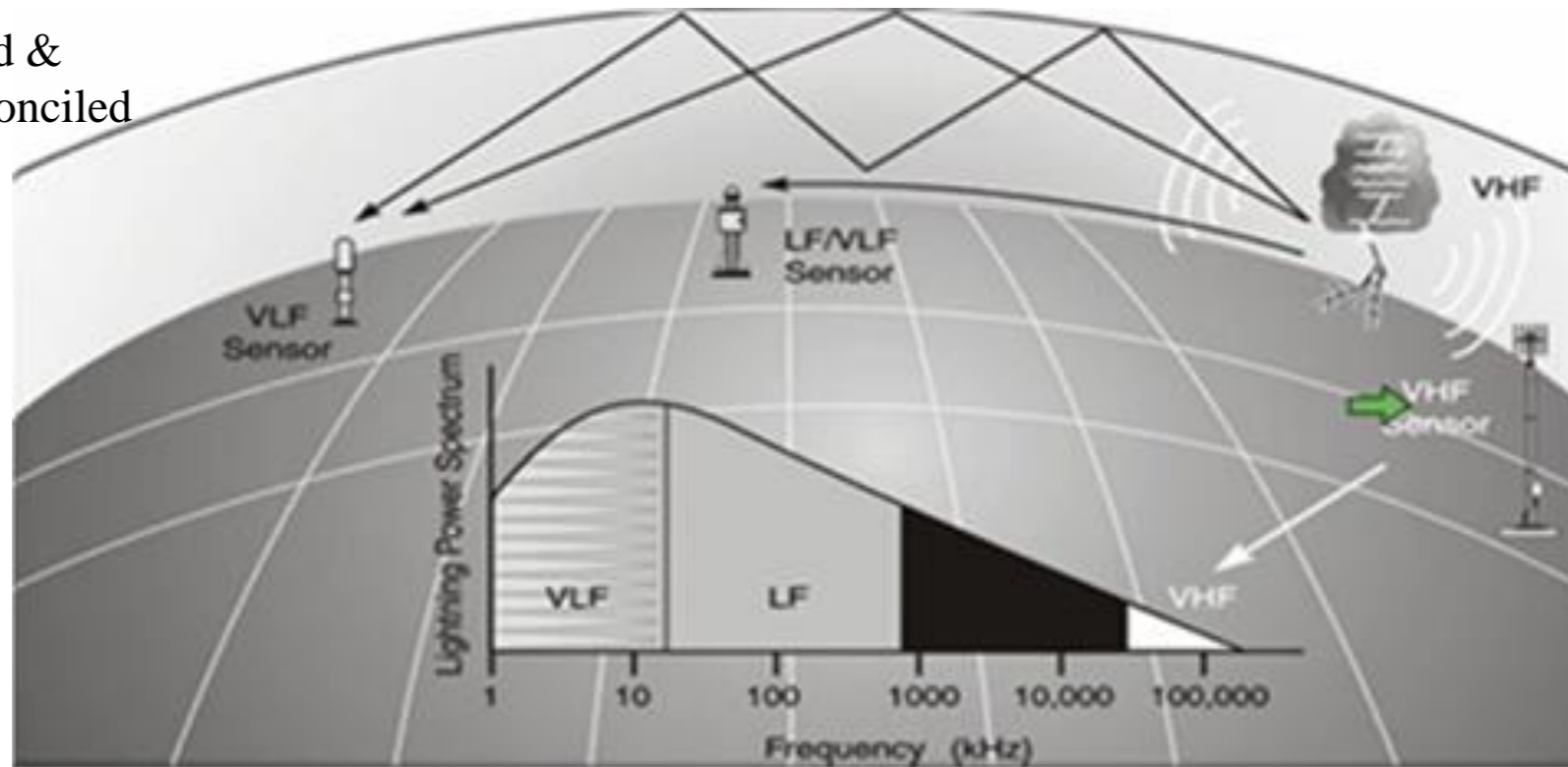





# NLDN Lightning Network

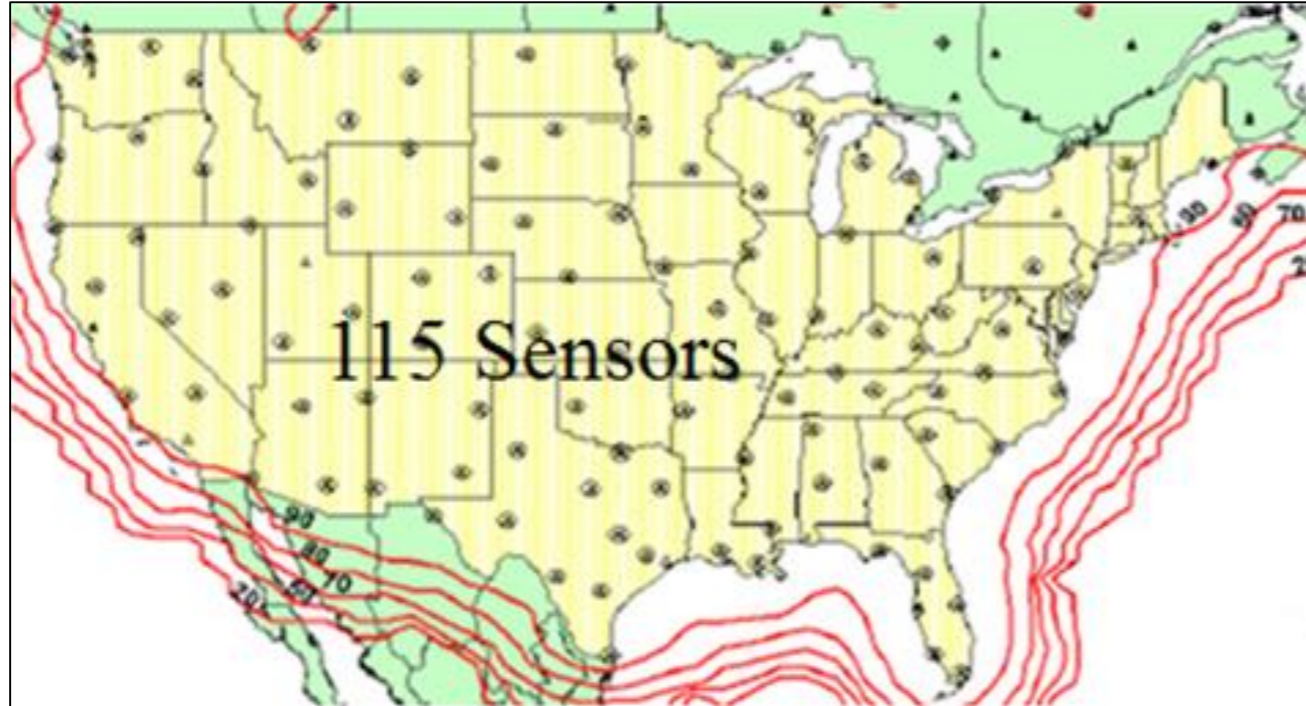

In Texas 12-24 sensors record each lightning strike

Location Accuracy: 150-600 feet

Lineament Accuracy: 10-100 feet

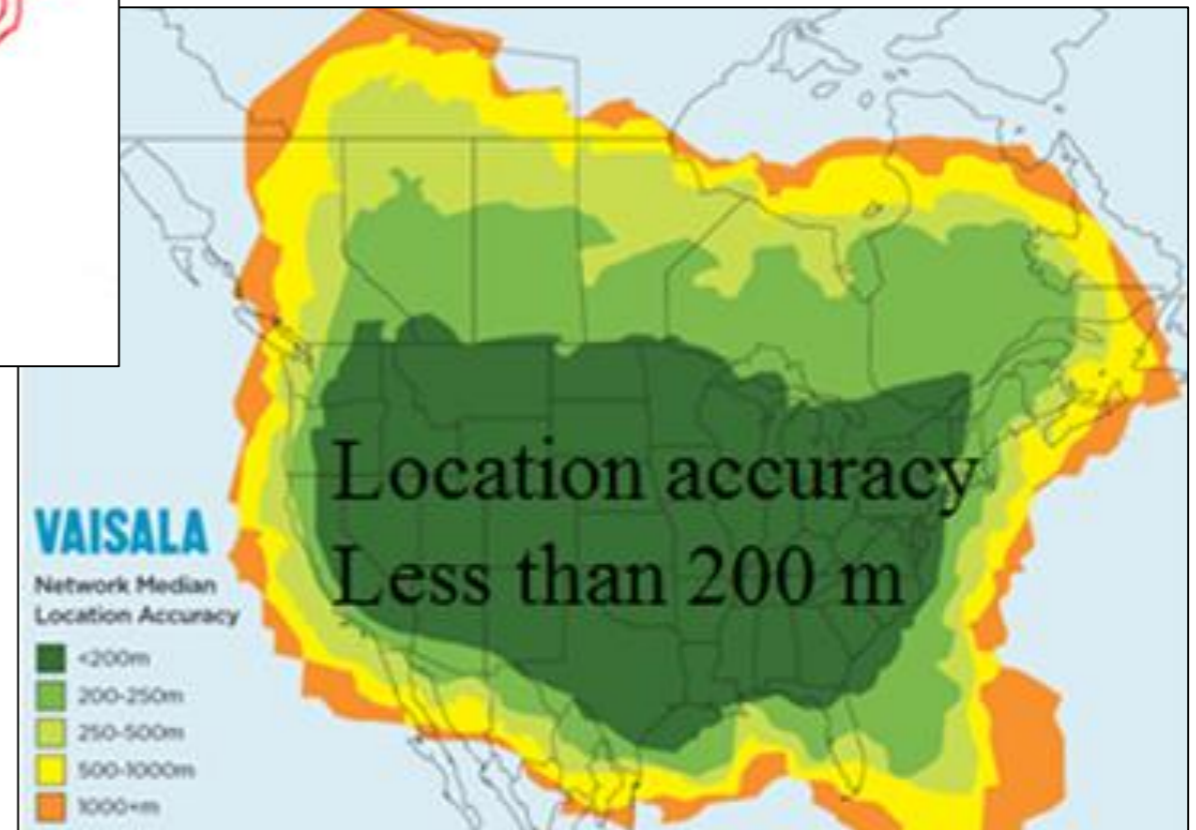

From 2016 Vaisala Webinar: Martin Murphy used with permission



# Lightning Data: A New Geophysical Data Type

Geophysical data types used for decades:

Gravity

Magnetics

Magnetotellurics<sup>Electrical</sup>

Electrical

Seismic

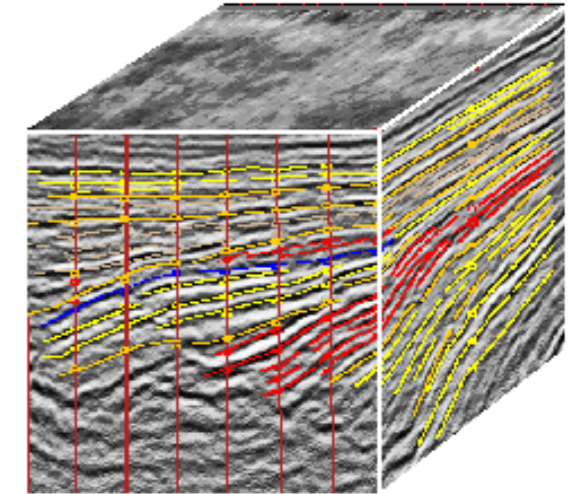
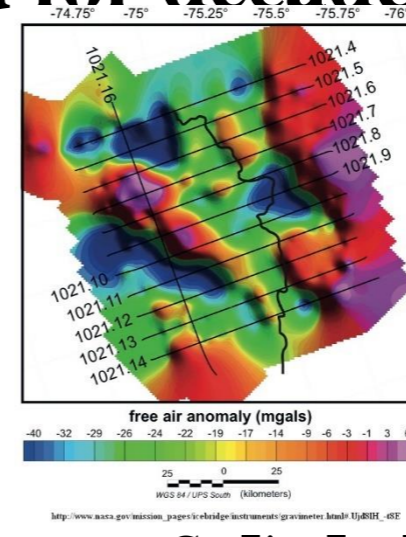
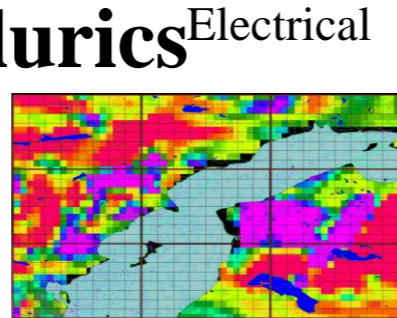
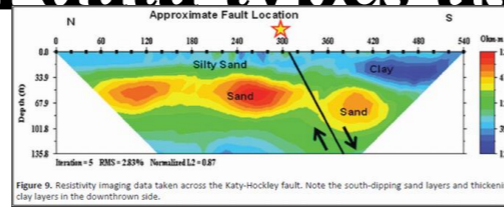

Dynamic Measurement has expanded these capabilities

Developing and patenting ways to data mine electrical information

Using existing lightning strike database

Mapping faults and creating geo-frame

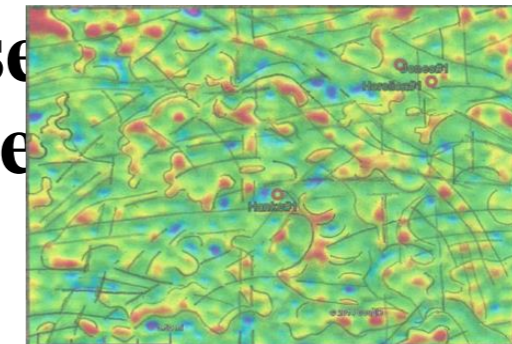

Surface Resistivity

Resistivity Volumes

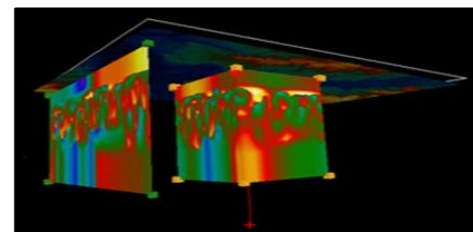





# Technical Comparison Geophysical Products

Discipline	Technique	Source	Receiver	Power
<b>Electrical Methods</b>	DC Resistivity	Required	Required	Low
	Electrical Resistivity Tomography (ERT)	Required	Required	Low
	Induced Polarization (IP)	Required	Required	Low
	Time-Domain IP	Required	Required	Low
	Complex Resistivity (CR)	Required	Required	Low
	Magnetotellurics (MT)	Passive	Required	Low
	Audio-Frequency MT (AMT)	Passive	Required	Low
	Controlled Source Electromagnetics (CSEM)	Required	Required	Medium
	Controlled Source Audio-Frequency MT (CSAMT)	Required	Required	Low
	Transient Electromagnetic Time-Domain EM (TEM)	Required	Required	Low
	Nano TEM Near Surface	Required	Required	Low
	Frequency-Domain EM Induction	Required	Required	Low
	AquaTrack (leak detection at dams, mines, etc.)	Required	Required	Low
	Self Potential (SP)	Passive	Required	Low
	Ground Penetrating Radar (GPR)	Required	Required	Low
Very Low Frequency Methods (VLF)	Passive	Required	Medium	
<b>Potential Fields</b>	Gravity	Passive	Required	High
	Magnetics	Passive	Required	High
<b>Seismic</b>	Earthquake Seismic	Passive	Required	High
	Refraction Seismic	Required	Required	Medium
	Reflection Seismic	Required	Required	Medium
	Micro-Seismic	Required	Required	Medium
<b>Satellite</b>	Spatial, Spectral, Temporal, & Geometric Resolution	Passive	Database	Low
	Radiometric Resolution: Thermal, Reflectance, Elevation	Passive	Database	Low
<b>Lightning</b>	National Lightning Detection Network (NLDN)	Passive	Database	High
	Global Lightning Database (GLD-360)	Passive	Database	High



# Economic Comparison Geophysical Products

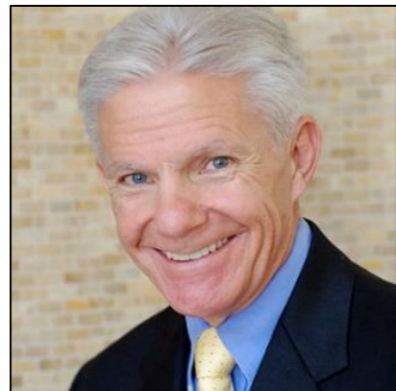

Michael Reed  
COO  
Dynamic Measurement

Swath Size - Line Spacing	1 km	200 m	100 m	50 m
Air Mag cost per 1 line km (price)	\$65	\$325	\$650	\$1,300
Air Mag cost per 10 line km (factor 1)	\$650	\$3,250	\$6,500	\$13,000
Magneto-Telluric cost per station	\$1,000			
EM cost per km	\$10,000			
Spec Seismic cost per sq km				\$10,000
New Seismic cost per sq km				\$85,000
Air Mag cost per 30 sq km mobilization costs > \$35,000	\$36,950	\$44,750	\$54,500	\$74,000
MT cost per 100, 500, 1000, & 2000 stations	\$100,000	\$500,000	\$1,000,000	\$2,000,000
EM cost per 30 sq km	\$300,000	\$1,500,000	\$3,000,000	\$6,000,000
Spec Seismic cost per 5, 10, 15, & 30 sq km	\$50,000	\$100,000	\$150,000	\$300,000
New Seismic cost per 5, 10, 15, & 30 sq km	\$425,000	\$850,000	\$1,275,000	\$2,550,000
<b>Lightning Analysis cost per 30 sq km</b>	<b>\$34,630</b>	<b>\$34,630</b>	<b>\$34,630</b>	<b>\$34,630</b>
Air Mag cost per 600 sq km	\$390,000	\$1,950,000	\$3,900,000	\$7,800,000
MT cost per 2000, 10000, 20000, & 40000 stations	\$2,000,000	\$10,000,000	\$20,000,000	\$40,000,000
EM cost per 600 sq km	\$6,000,000	\$30,000,000	\$60,000,000	\$120,000,000
Spec Seismic cost per 600 sq km	\$300,000	\$1,500,000	\$3,000,000	\$6,000,000
New Seismic cost per 600 sq km	\$2,550,000	\$12,750,000	\$25,500,000	\$51,000,000
<b>Lightning Analysis cost per 600 sq km</b>	<b>\$97,740</b>	<b>\$97,740</b>	<b>\$97,740</b>	<b>\$97,740</b>

Price





## 2. Lightning Database Analytics

- Typical projects have millions of lightning strikes.
- All projects to date have tied available surface and subsurface control.
- Attributes are measured or calculated for lightning strike locations, then contoured or gridded or interpolated in three-dimensions.
- Lightning strike density and electrical attribute values cluster, and these clusters are somewhat consistent over time.
- Lineaments, like fault scarps, have been mapped with 30 foot horizontal location accuracy.



Copyright © 2017  
Dynamic Measurement LLC.



University of Utah 13

03 March 2017



# Lightning Measurements



- Location
- Time and Duration
- Rise Time
- Peak Current
- Polarity
- Peak-to-Zero
- Density

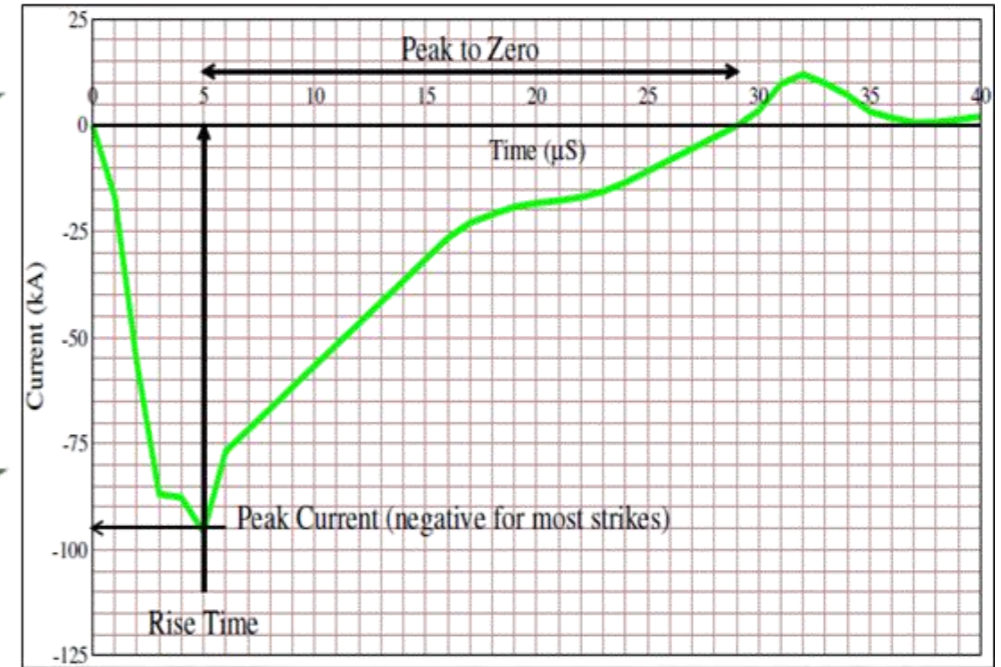
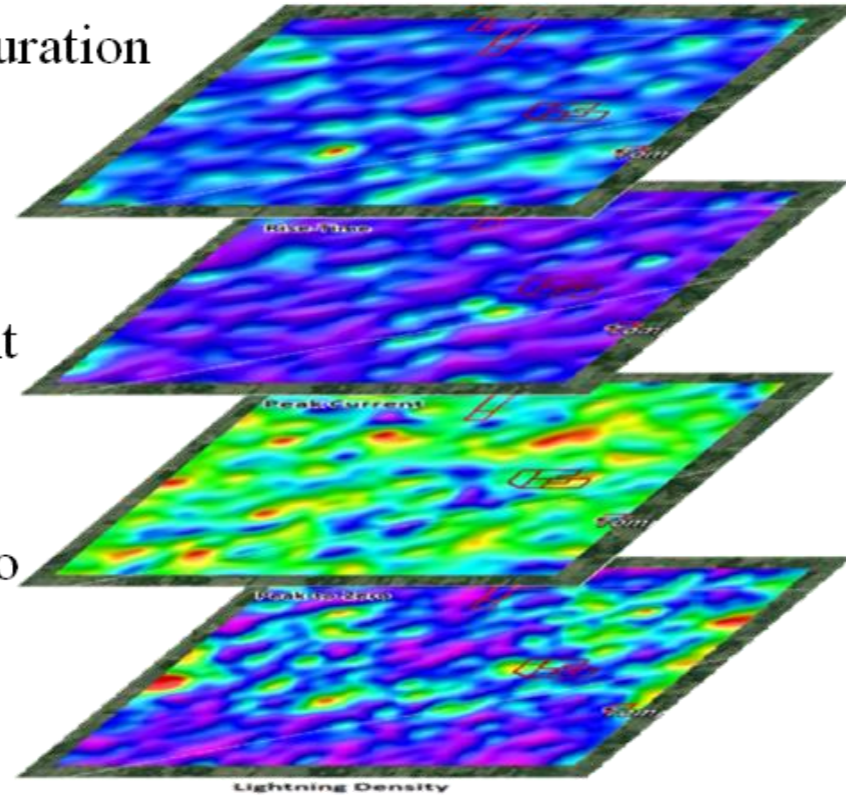

- Other attributes calculated from these measurements.
- The time of the lightning strike is correlated with solar and lunar tides.
- Measurements separated by time.





# The Atmosphere is an Effective Insulator

The electrical conductivity of air is  $0.3-0.8 * 10^{-14} \text{ S.m}^{-1}$  (Siemens per meter).

The effectiveness seen in air's common use separating high voltage transmission lines from the ground, from towers used to support the lines, and from lines carrying different voltages and different phases.



# Lightning Occurs when there is Sufficient Charge to Bridge Atmospheric Capacitor

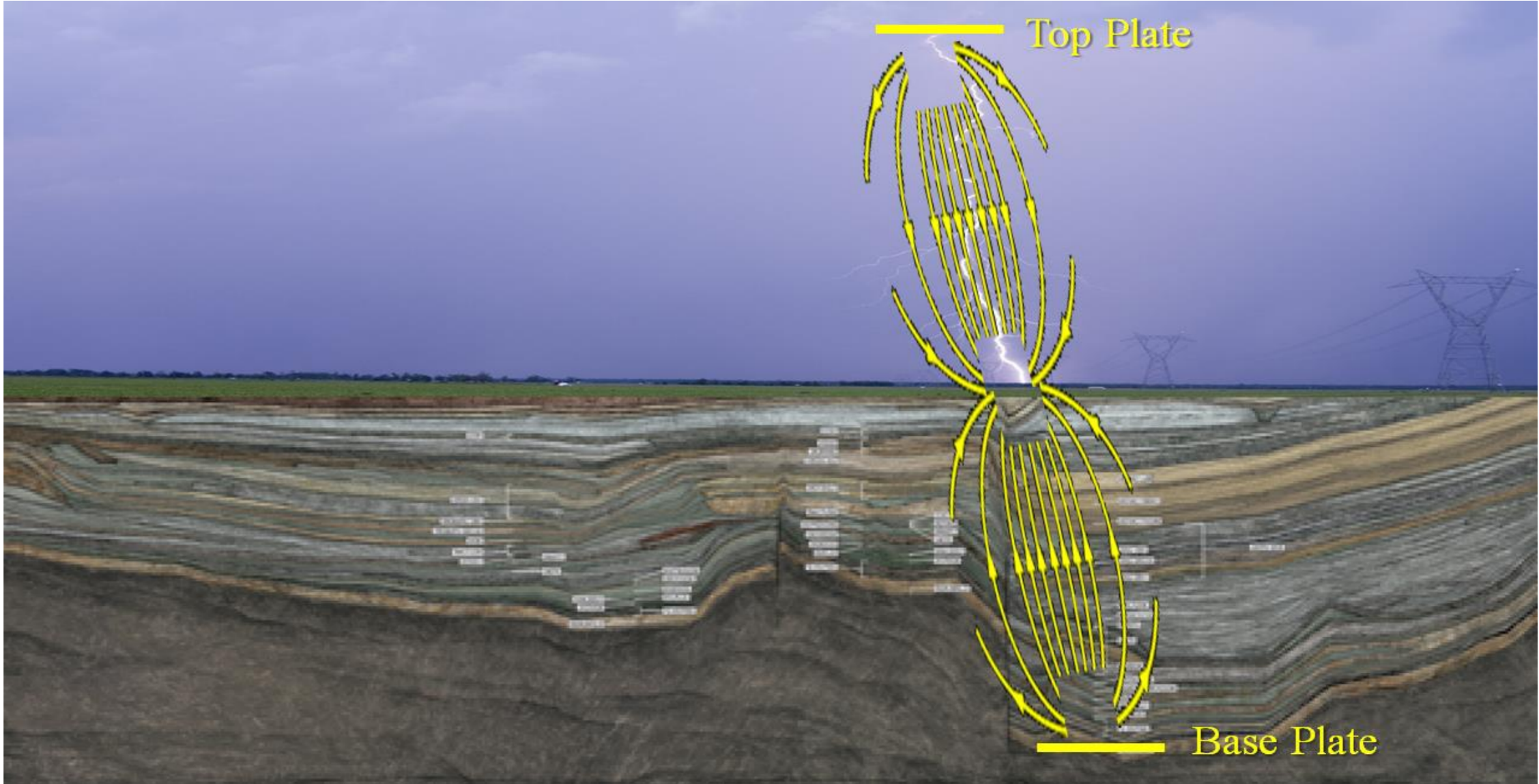





# The earth is much more conductive than air

Assuming a typical sedimentary rock has 5% porosity, the electrical conductivity of rocks is  $5.0 \times 10^{-4} \text{ S.m}^{-1}$ , or about  $10^{10}$  times the conductivity of air.

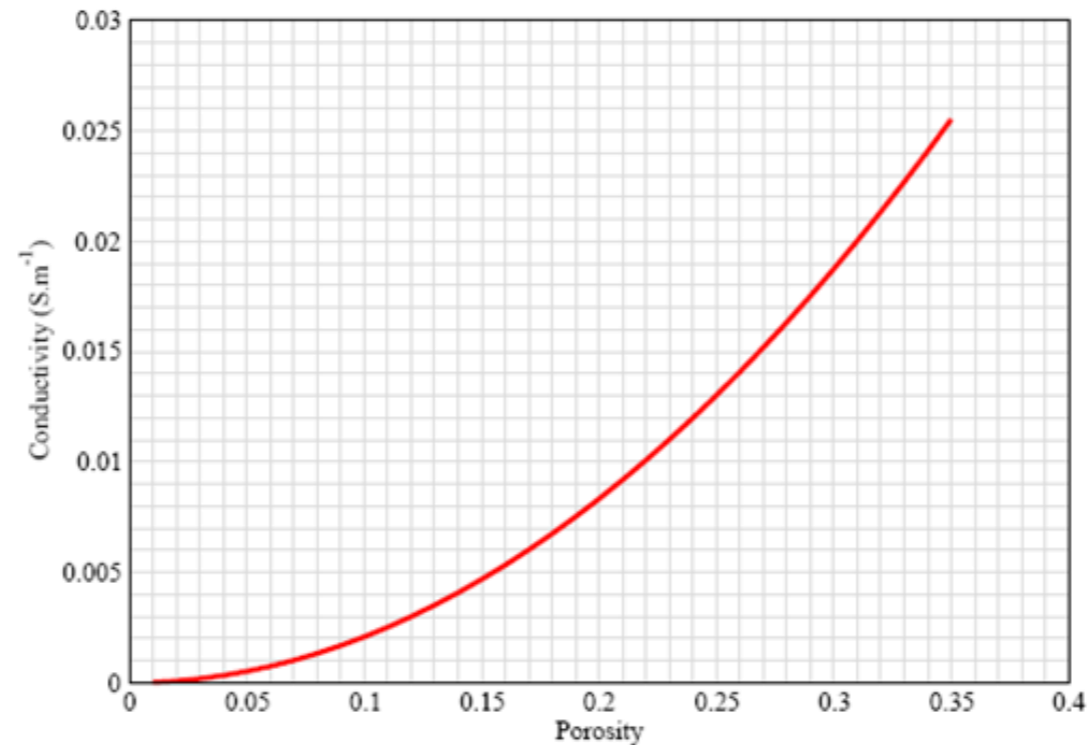

Geothermal temperature increases, further increase conductivity

Rock Conductivity Graph computed for a porous rock with 100% brine saturation using Archie's equation



# Telluric & Atmospheric Currents make up the Earth's Electrical System



03 March 2017

2 issued patent abstracts in Appendix

Copyright © 2017  
Dynamic Measurement LLC.





### 3. Rock Property & Attribute Maps & Volumes



#### Key Assumptions:

1. Lightning occurs when there is sufficient charge to bridge the capacitor.
2. Lightning is affected by geology to a depth proportional to cloud height, as derived from Peak Current

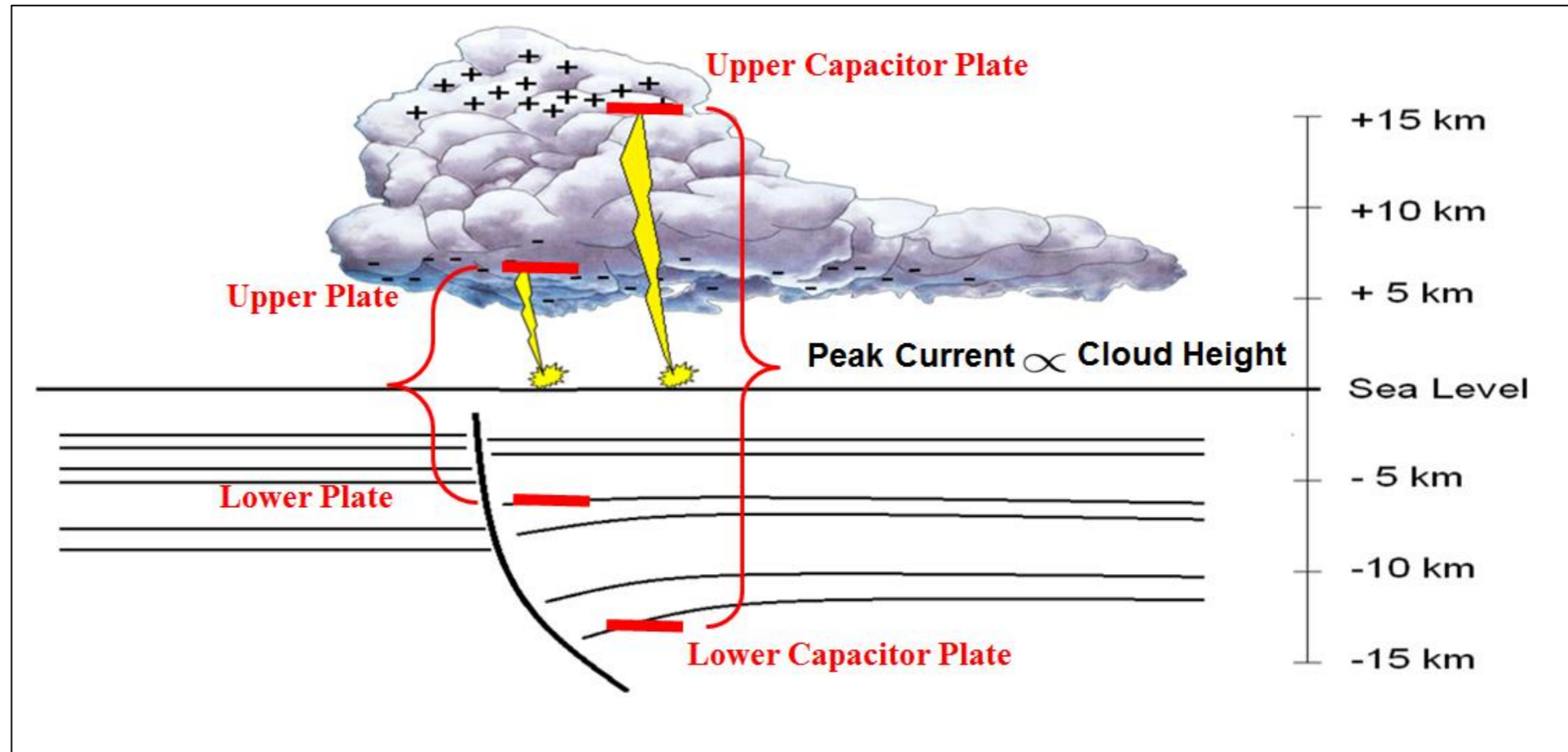



# Relaxation Oscillator Physics and Lightning (a giant neon tube)

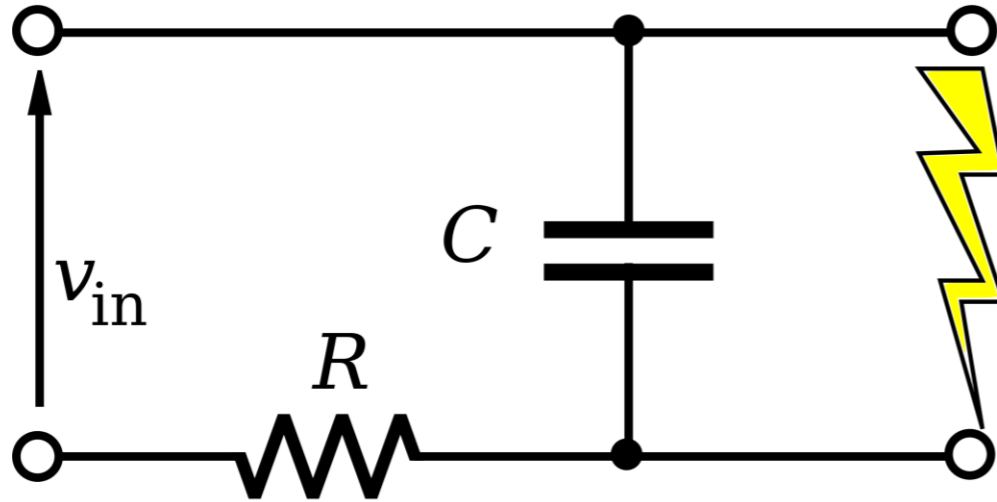

- The atmospheric capacitor is like a relaxation oscillator
- Just an additional resistance ( $R_2$ ) limiting the current

- $R_2$  is the resistance between the lightning strike point and the bottom plate of the capacitor

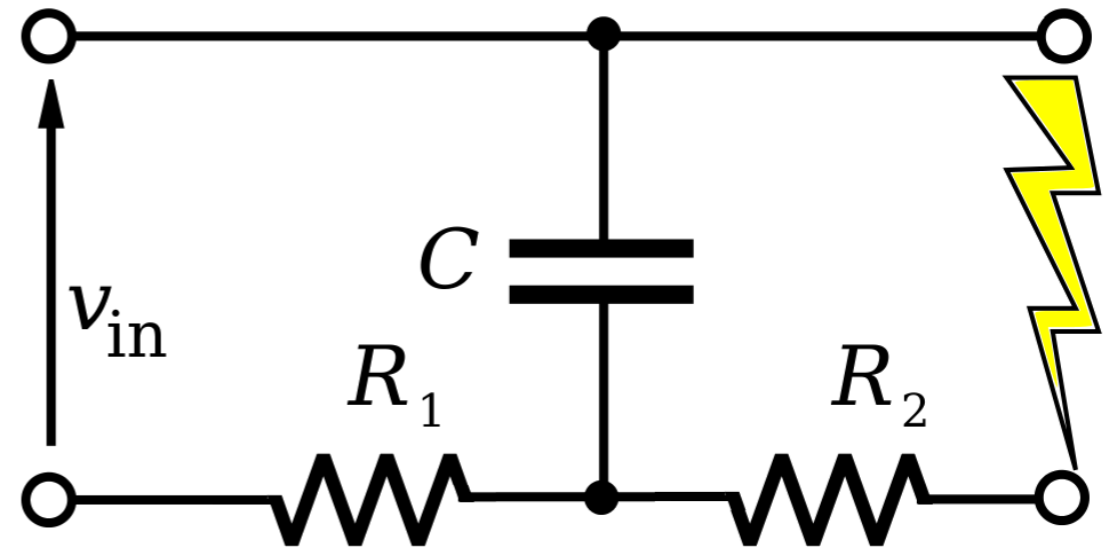





# Lightning and the Induced Polarization Effect

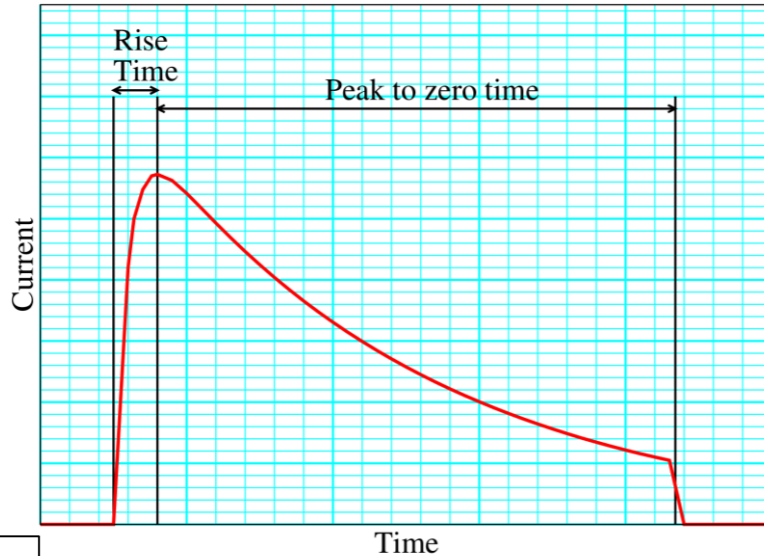

- Lightning does not have a square waveform
- But it does have a very steep onset
- Variations in the onset as measured (rise-time) show the IP Effect

- By treating this steep onset as charging a capacitor ( $C_2$ ) through a resistor ( $R_3$ ), an apparent capacitance can be calculated.
- From the apparent capacitance a value for apparent permittivity can be calculated

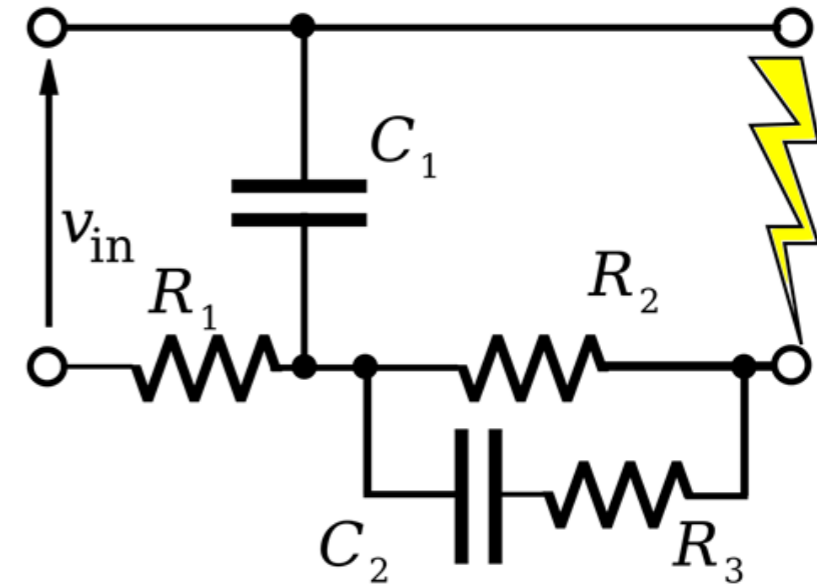

Les Denham  
Chief Geophysicist  
Dynamic Measurement



# Es Xplore Electro seismic Technology

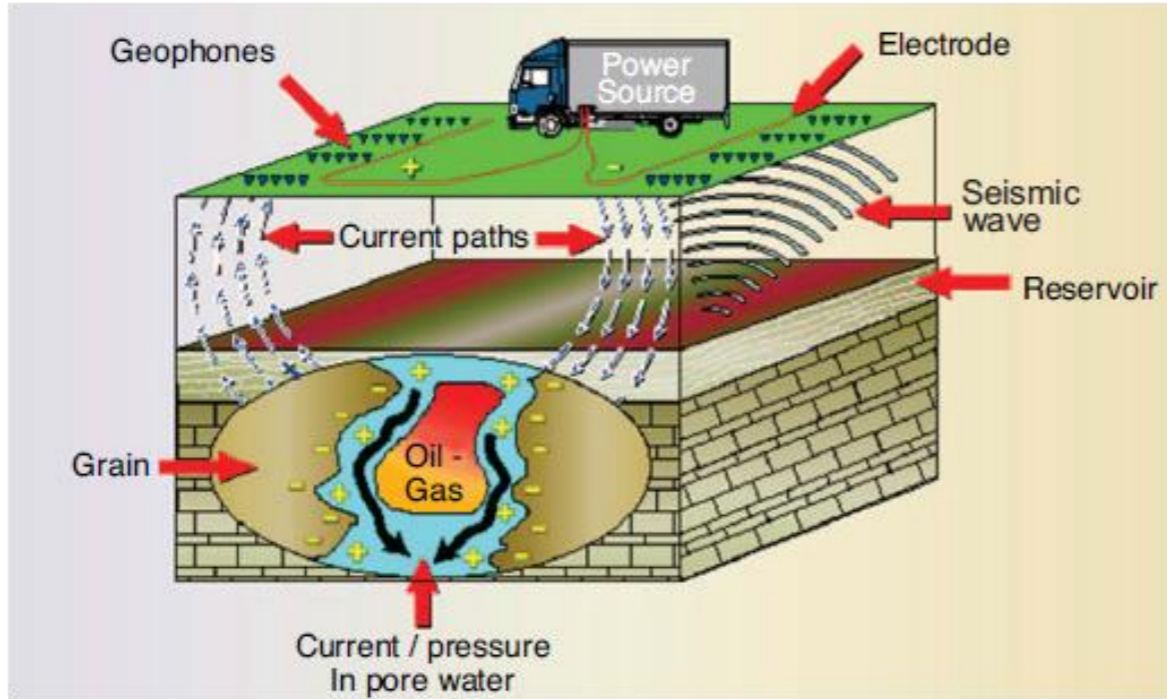

Figure 1. Description of the ES method. A current injected into the subsurface creates local field gradients at discontinuities in electrical properties. Applied fields couple to internal rock fields, including fields in the dipolar boundaries on pore surfaces. This electrokinetic coupling displaces the dipolar fluid layers causing relative movement or pressure generation in the grain space.

From Field test of electorseismic hydrocarbon detection, Geophysics, Vol. 70, No. 1, Jan-Feb 2007.

Bakken example in Appendix

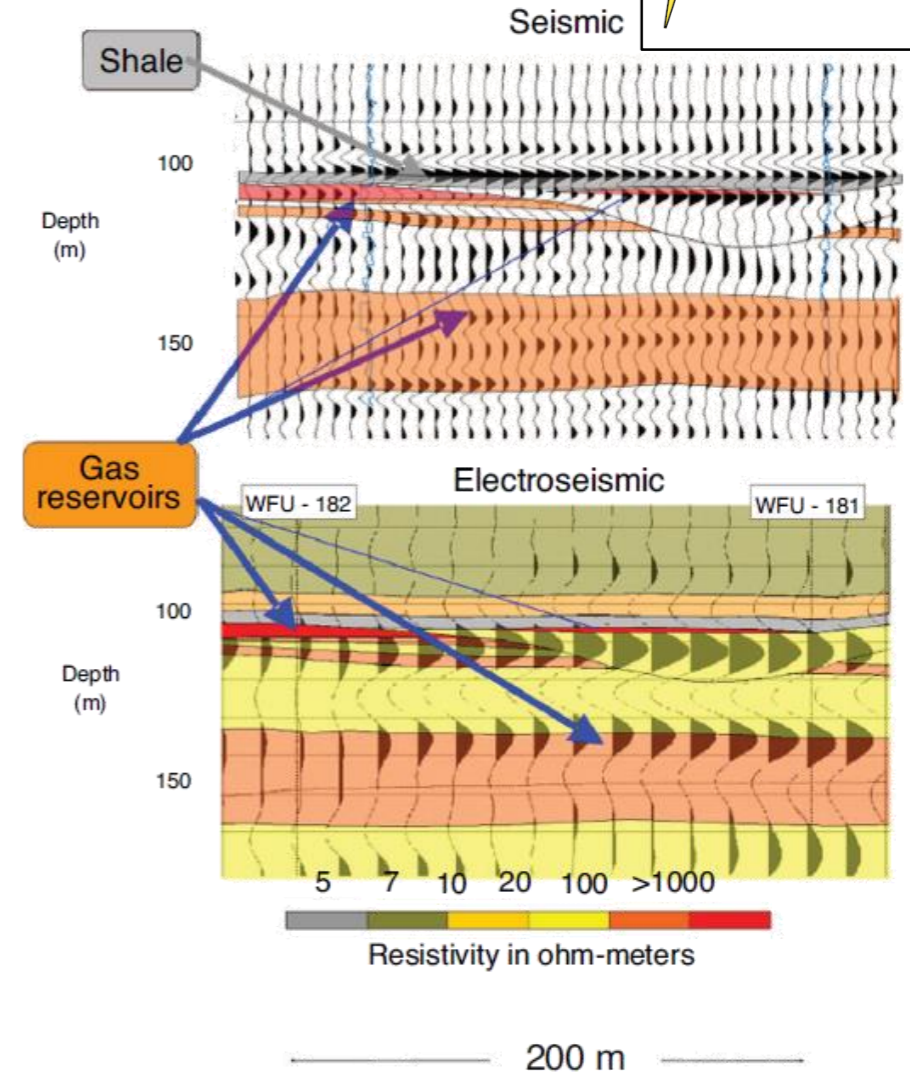

Figure 3. Webster field. Seismic, ES, and stratigraphic interpretation. The upper seismic display from the 3D seismic survey shows large amplitude response to the shale above the gas sands. The lower ES display shows large amplitude response to the gas sands.





# Stress-Induced Currents in the Laboratory



**Although silicate minerals are primarily insulators, most can behave as semiconductors because they contain dormant electronic charge carriers, i.e. electricity that can be activated by stress.**

**When rocks are subjected to stress, first positive and then negative charge carrying currents are produced (positive or “h holes” and electrons respectively).**

**These stress-induced currents flow toward the unstressed region of rock samples and from the interior to the rock’s exterior, ultimately ionizing the air.**

**Thus, faulted areas offer a plentiful supply of dormant charge carriers that when triggered by the attraction of overhead storm clouds, can provide the necessary current flow, in the form of “streamers,” to attract opposite charged step-leaders.**

Dr. Friedemann Freund, NASA Ames Res. Ctr. , Mountain View, CA; Dept. of Physics, San Jose State Univ. San Jose, CA



# Creating a Rock Battery in the Lab

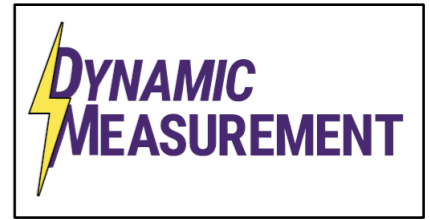

## Stress-Induced Currents

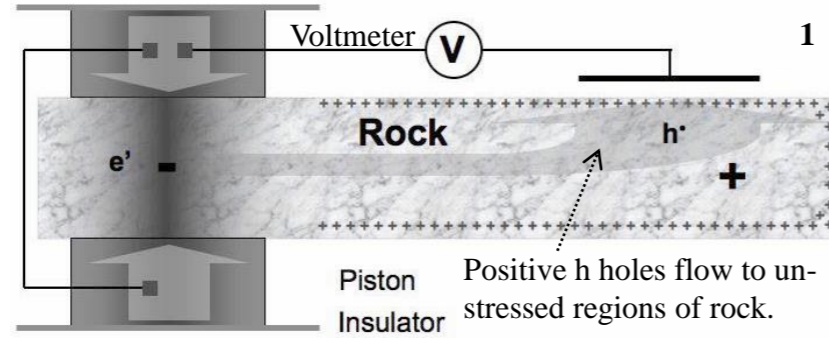

Set-up to measure the positive surface potential with a capacitive sensor.

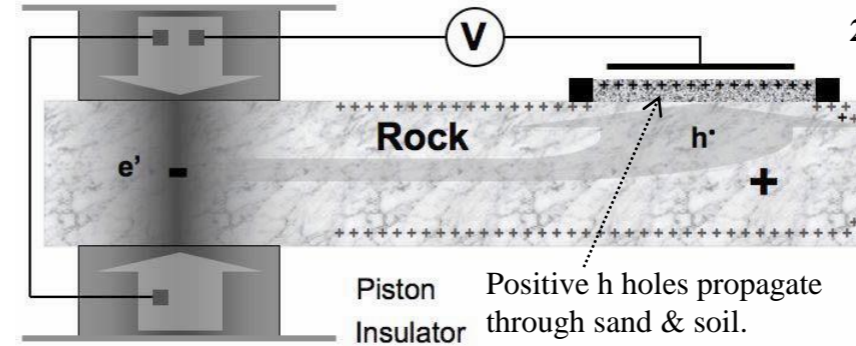
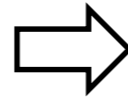

Potential difference measured between unstressed rock & piston, indicating build-up of surface & subsurface charge.

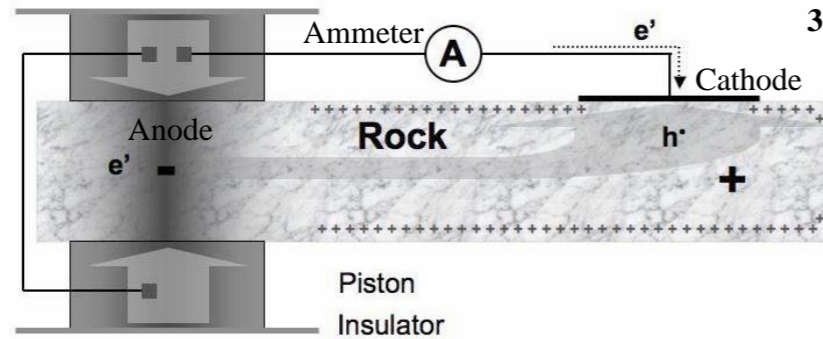

Battery circuit completed by placing copper contact (cathode) on rock. Ammeter measures current.

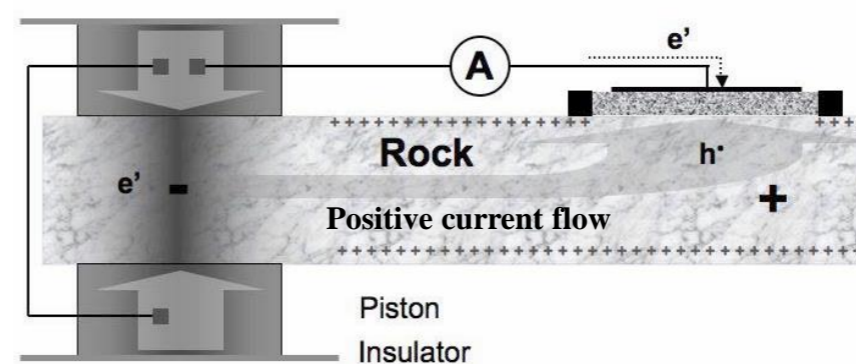
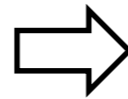

Demonstrates that positive h hole current also flows through sand and soil.

**“Loading simulates tectonic stresses causing existing dislocations to move & new ones to be generated in response to shear forces acting on mineral grains.”**

**“Dislocations activate h charge carriers alongside electrons” (Freund, 2002; Freund et al., 2006)**

Figures modified from Friedemann Freund, “Toward a unified solid state theory for pre-earthquake signals,” Acta Geophysica 58(5):719-766 · October 2010.





# Skin Depth does not Control Lightning Penetration



## Charging Telluric Currents:

- Lightning strikes are passive energy pulses, and contain all frequencies.
- The skin effect of high frequency information recorded in ~50 microsecond total-wavelet time does not control the depth electrical energy interacts with telluric currents.

## Interval of Interest:

- Traditional lightning does not occur in clouds less than ~1,500 feet in height, nor for clouds higher than ~30,000 feet.
- The depth interval where lightning volumes are useful is typically from 1,500-30,000 feet.

## Data Distribution:

- Maps delivered as X,Y, attribute ASCII files
- Volumes converted to SEG-Y files for workstations.
- Volumes interpolated to match aeromagnetic or 3-D seismic surveys.
- Resulting rock property or lightning attribute volumes are overlaid on the seismic or other geologic cross-sections like a velocity volume.

## 4. Lightning Analysis & Attributes

1. Analysis area selected.
2. Patented and Patent-Pending Processes produce maps and volumes of derived rock properties and lightning attributes.
3. Existing geology and geophysics integrated with new data.

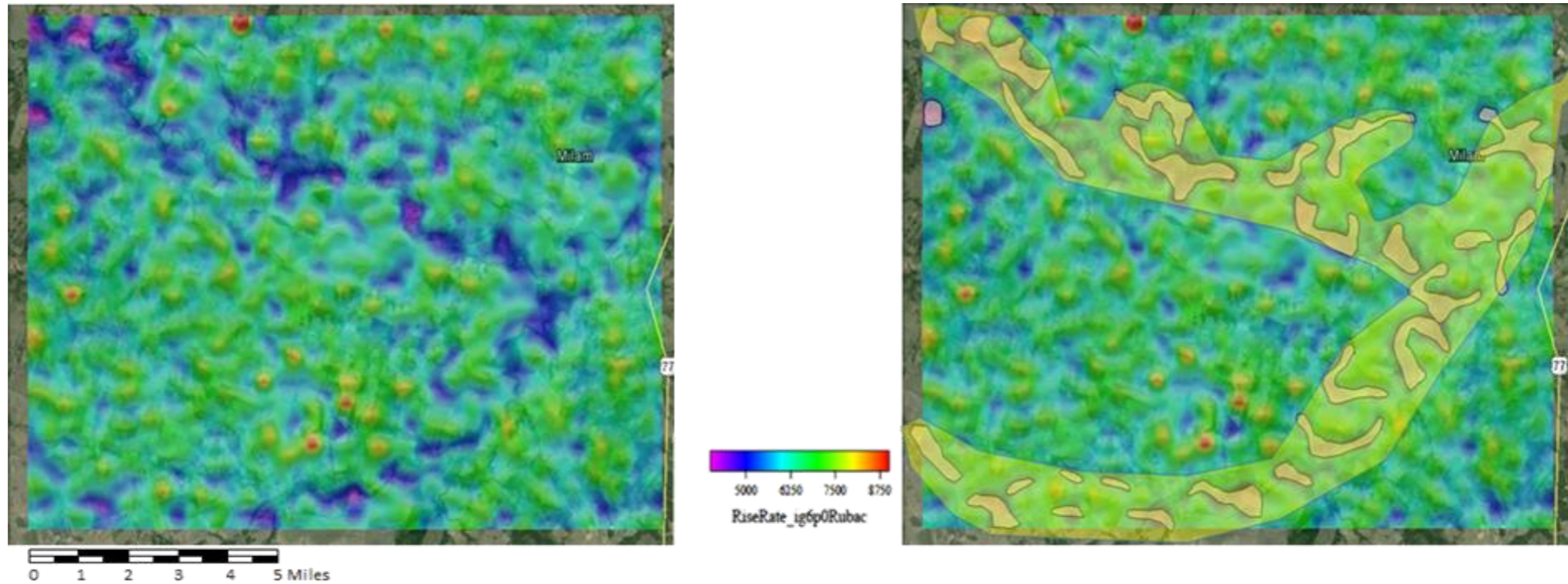

Lightning Attribute: Rate of Rise-Time – Milam County, Texas





# Lightning is tied to all aspects of the Earth's Electrical System



Top Plate

Powerline

Pipeline

Base Plate





# Powerline Leakage occurs at Geomagnetic Hot Zones (GHZ)



**GHZs include concentrated sub-surface currents that interact with pipelines speeding up corrosion and impact integrity. Natural gas with high water content exacerbates the problem.**

Top Plate

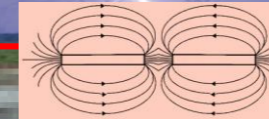

Pipeline

Base Plate





# Powerline Leakage occurs at Geomagnetic Hot Zones (GHZ)



**Just as GHZs attract more lightning strikes, they pull on electrical current during power transmission which leads to Leakage**

Top Plate

Powerline

Leakage

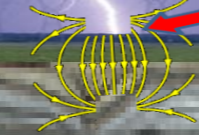

Base Plate





# 5. Study Area around Corpus Christi

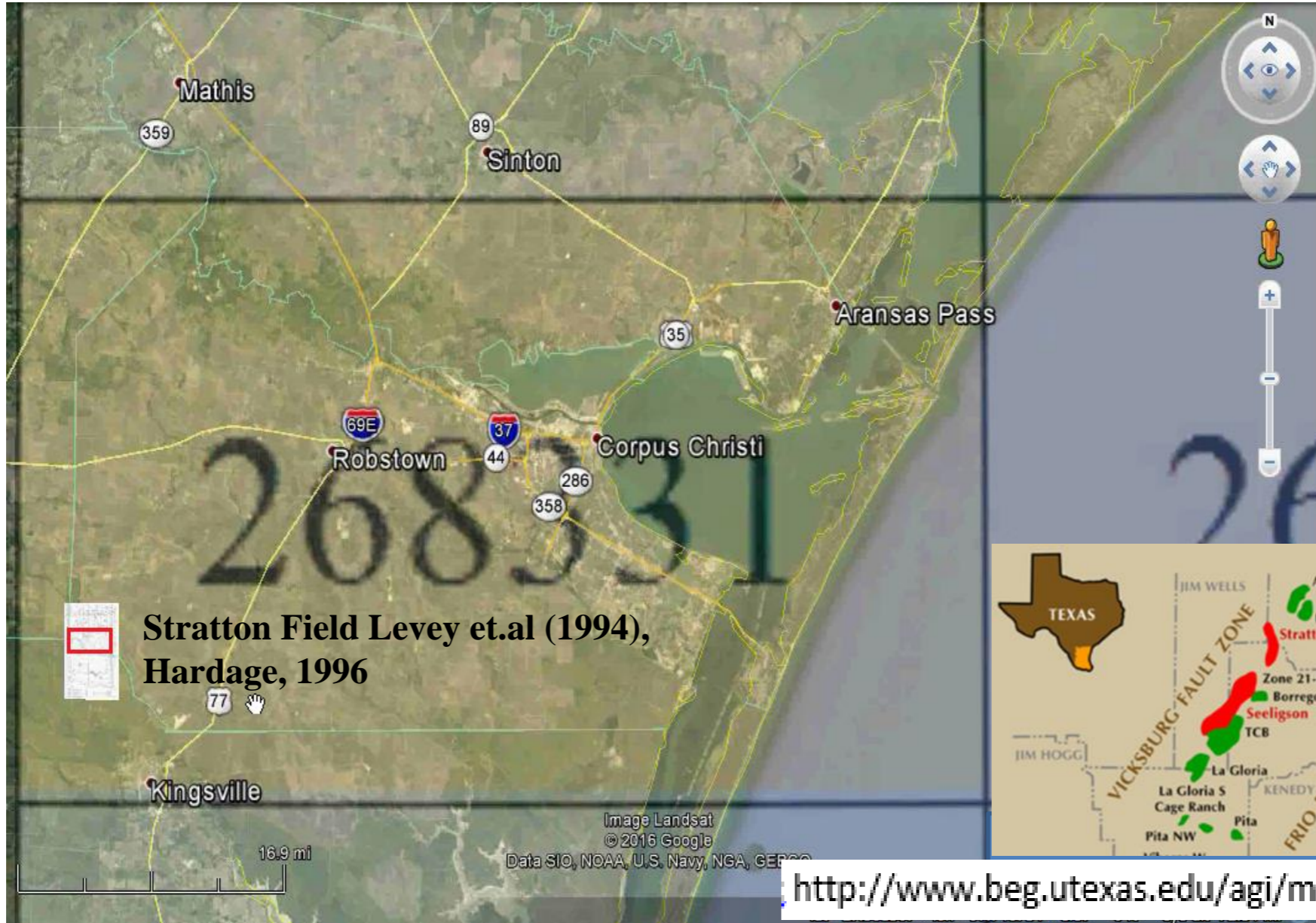

<http://www.beg.utexas.edu/agi/mod08/m08-kb02.htm>





# Stratton Seismic Sections, South Texas



Frio Horizons  
Fluvial – Deltaic  
Sands

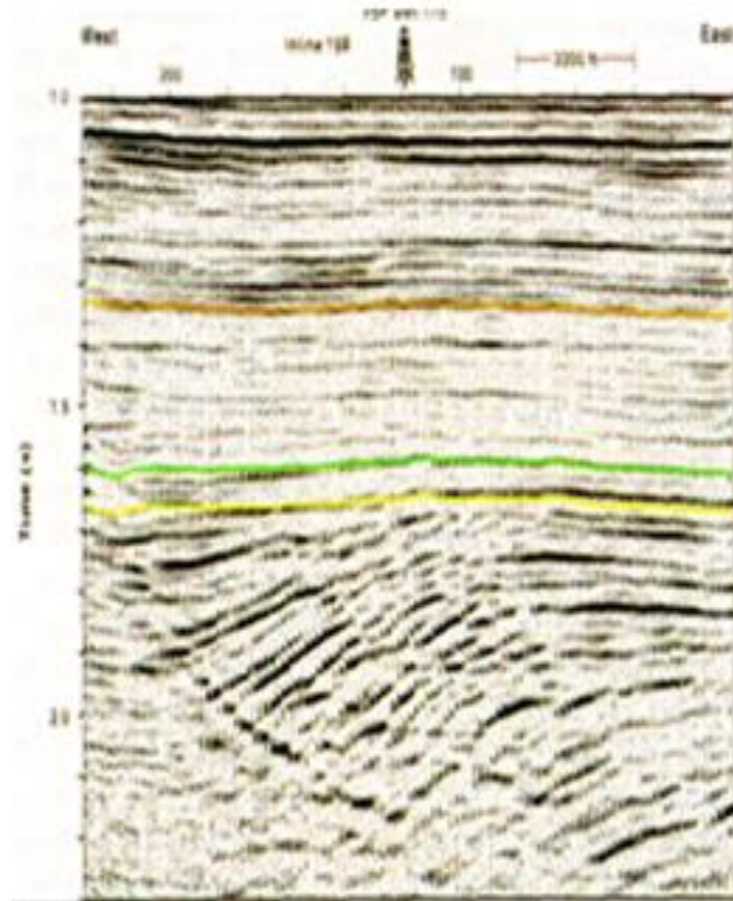

Published BEG Stratton Data to 2.3 seconds  
(Hardage, 1986)

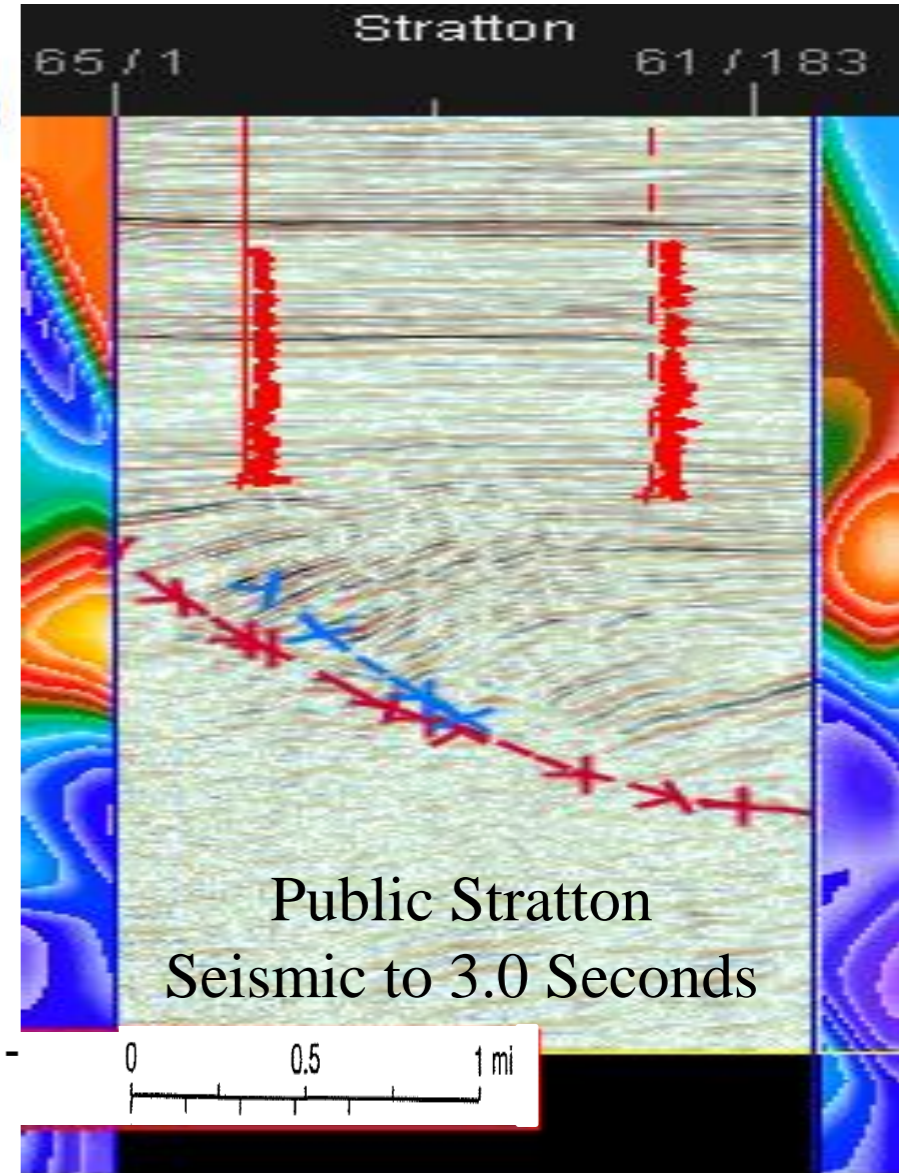

Public Stratton  
Seismic to 3.0 Seconds



Louie Berent,  
Geophysicist  
Kathy Haggar  
Geologist  
Dynamic Measurement





# Stratton Apparent - Resistivity Sections

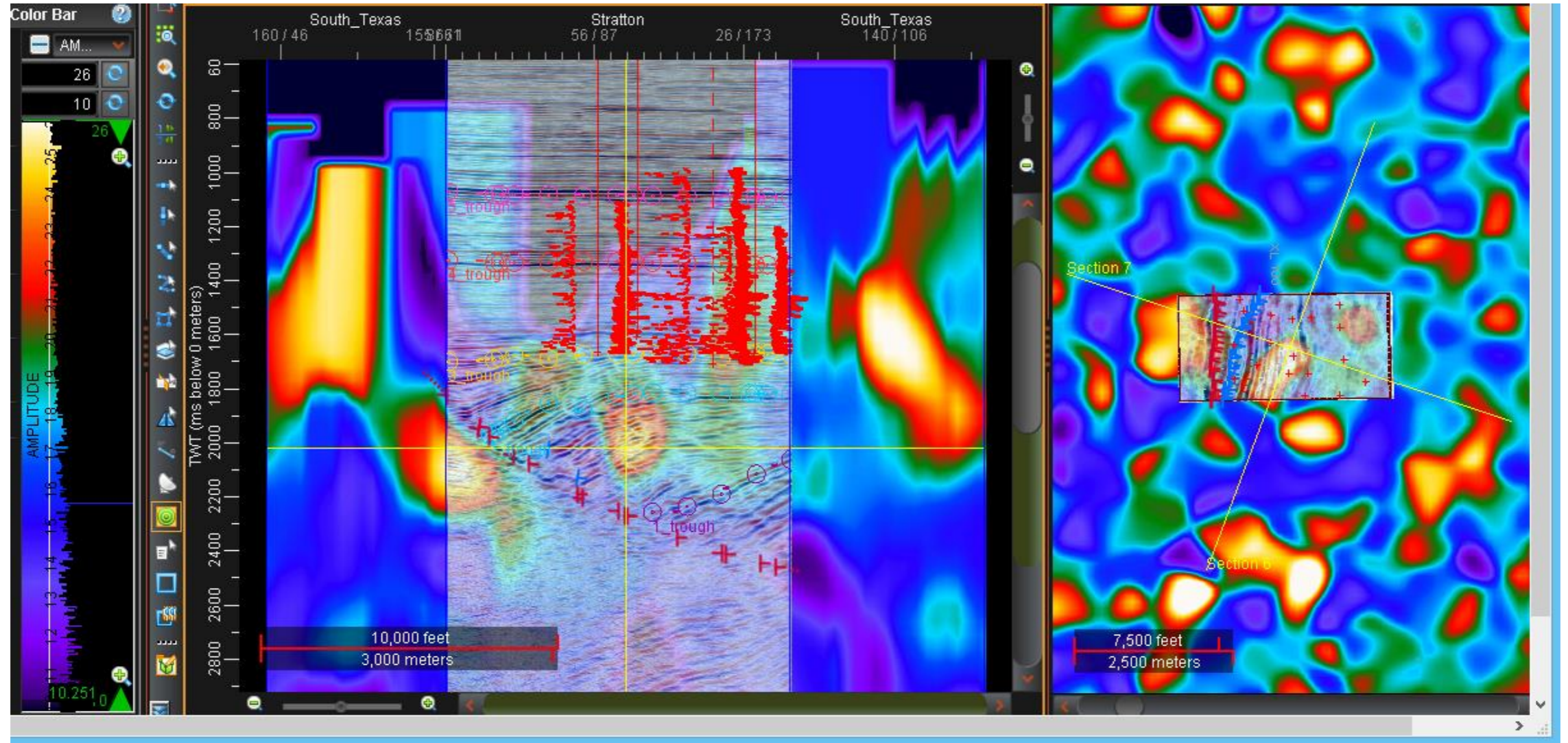

Working on calibrating depth and calculated vs. measured resistivity





# Study Area - Geology and Structure Corpus Christi from Ewing (1986)

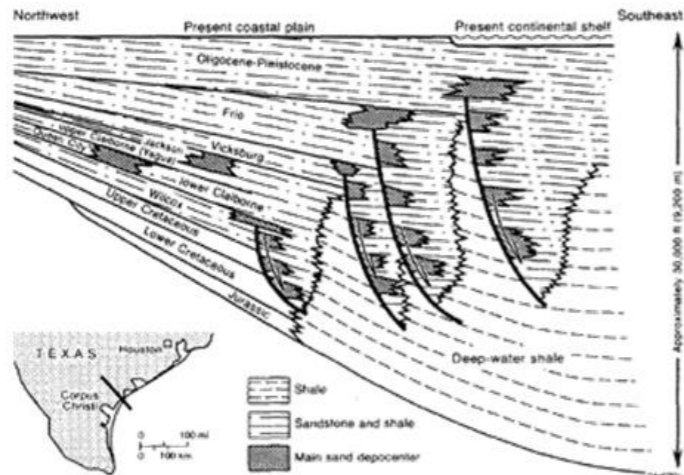
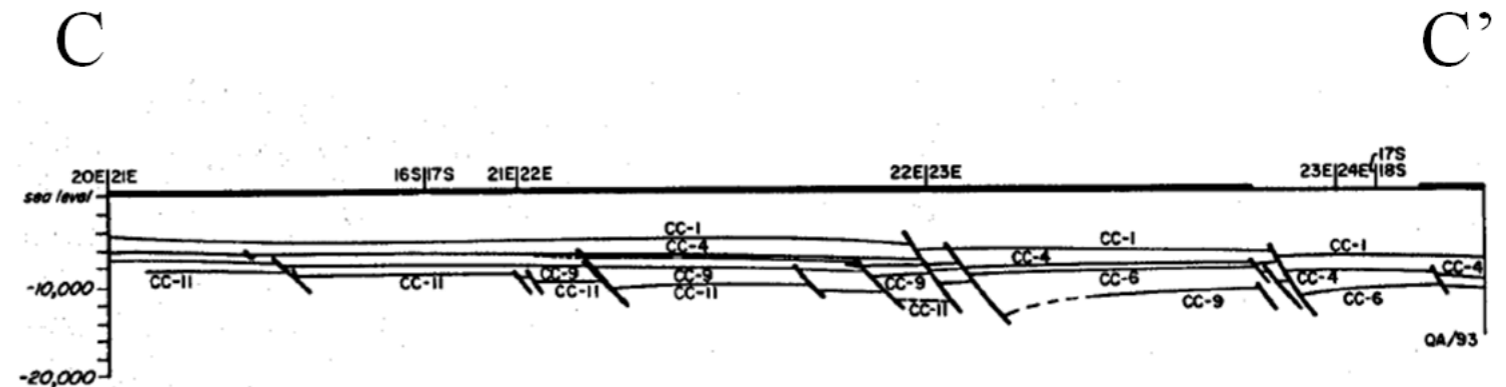
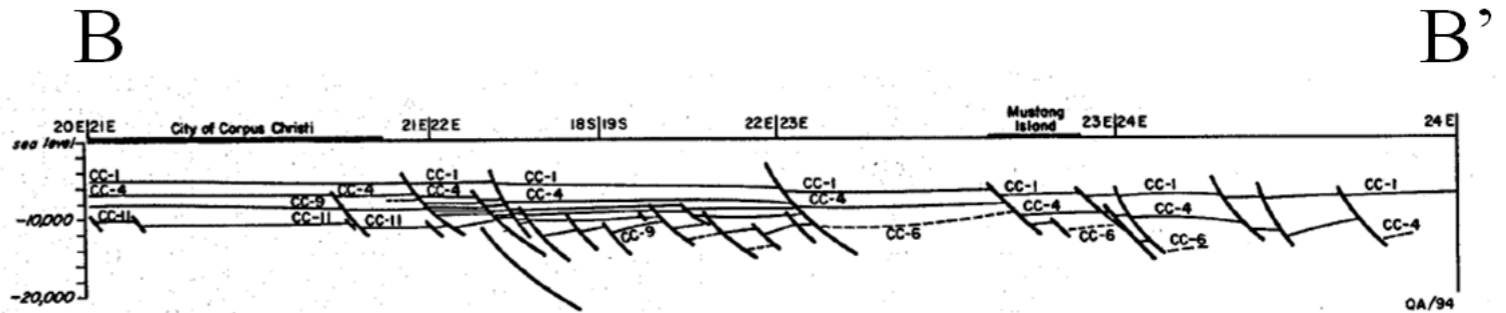
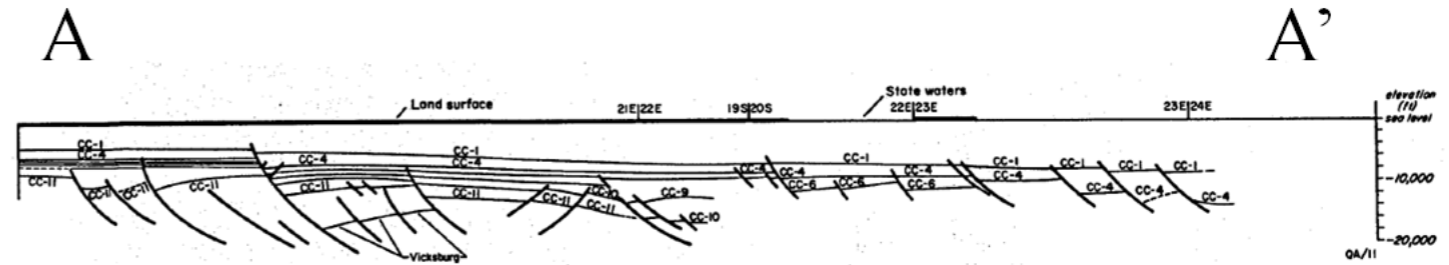

From Levey, et al,1994  
Bebout and others,1982

Copyright © 2017  
Dynamic Measurement LLC.

University of Utah 33





# 2016 Lightning-Derived Resistivity Cross-Sections Match Geology on 1986 Ewing Interpretation Overlay

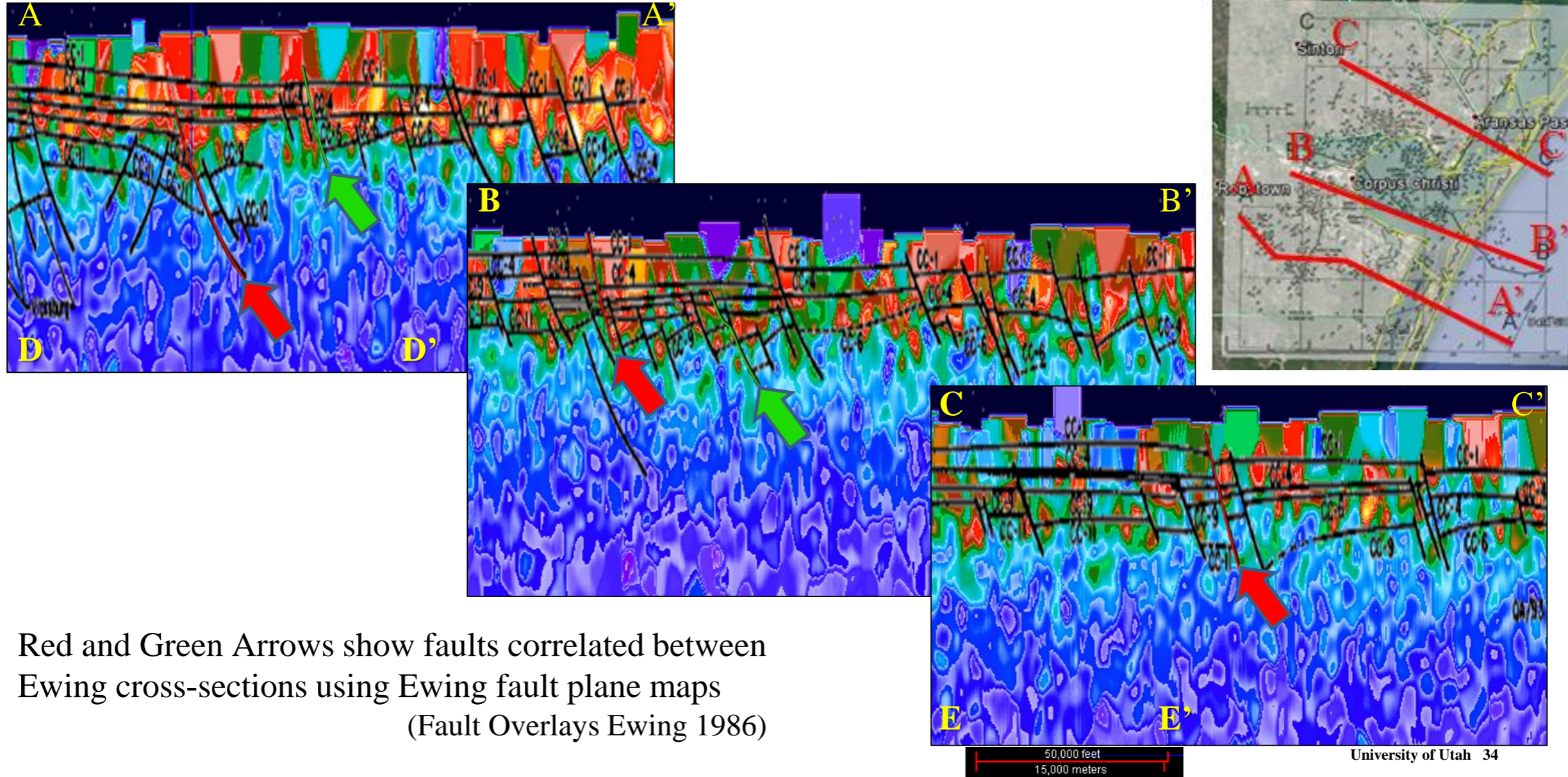

03 March 2017





# D-D' Close-Up on Graben on A-A' without overlay

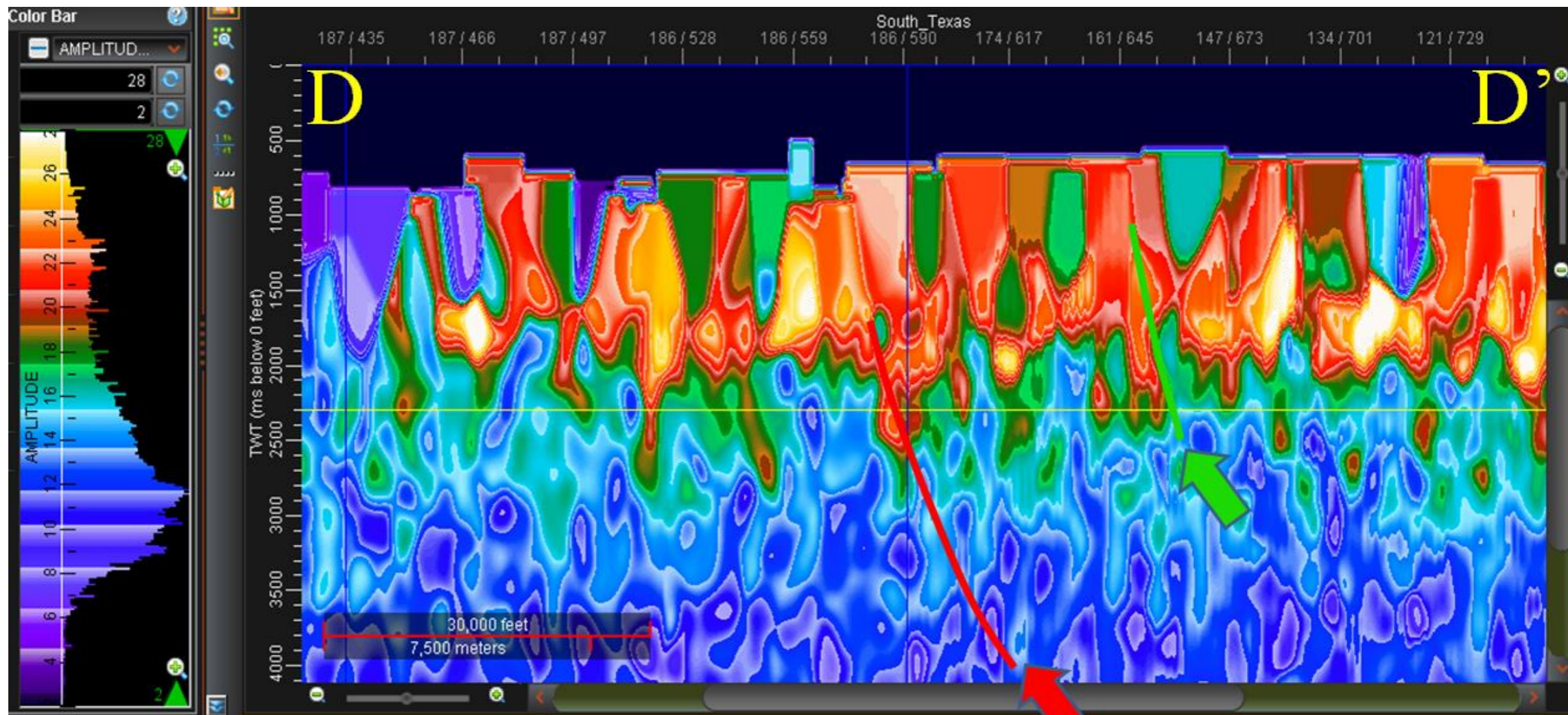

Red and Green Faults were major faults on Ewing's maps. Note high apparent-resistivity events (bright) appear to have plumes above these faults.





# D-D' Close-Up on west Graben

Interpretation 1986 by Tom Ewing, Apparent Resistivity 2016 from Lightning Databases

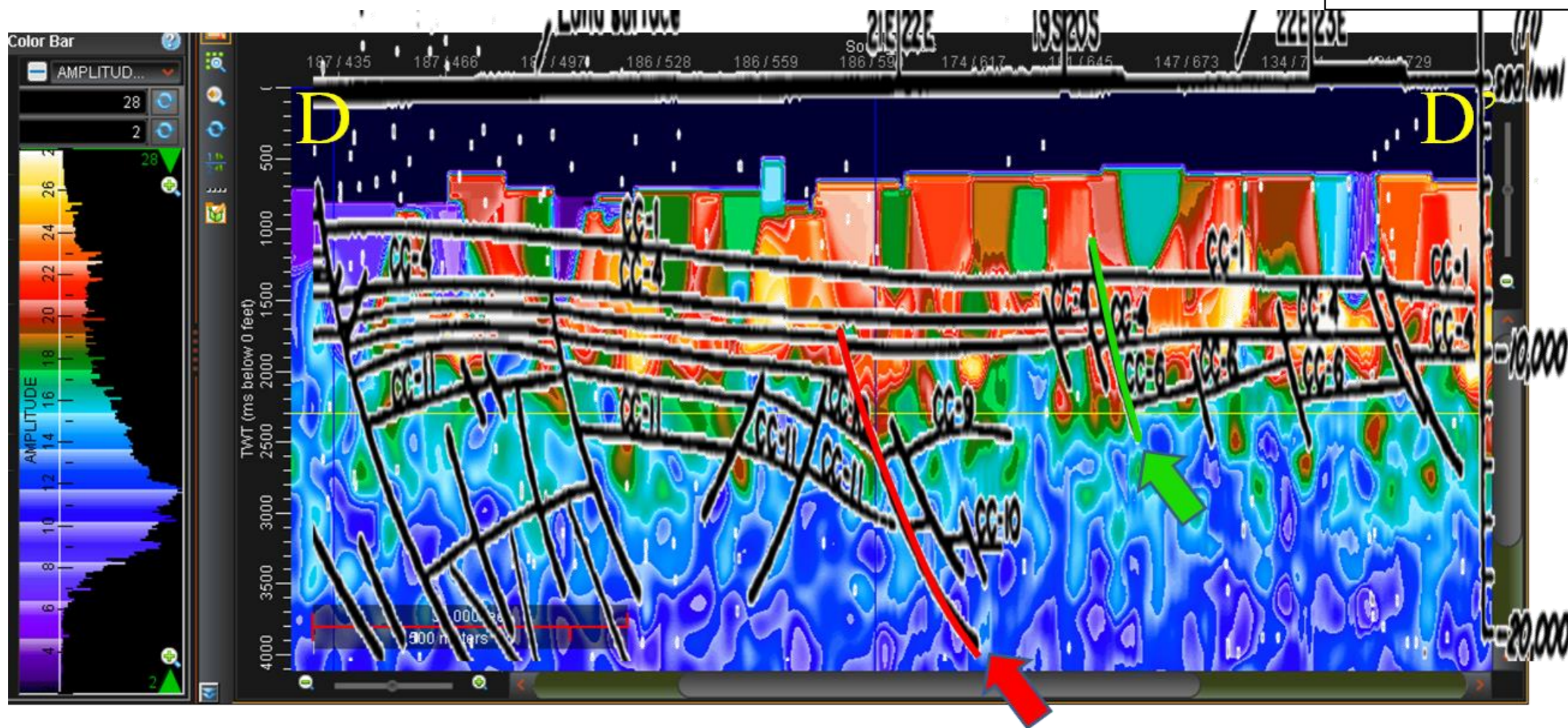

Note: interpretation by Tom Ewing in 1986. The resistivity section calculated from lightning in 2016. Co-located sections show breaks where faults were interpreted. There are resistivity plumes tied to faults.





# E-E' on the Northwest End of Ewing's C-C'



Note offsets in adjacent  
“Packages” of Higher Values  
of Apparent Resistivity

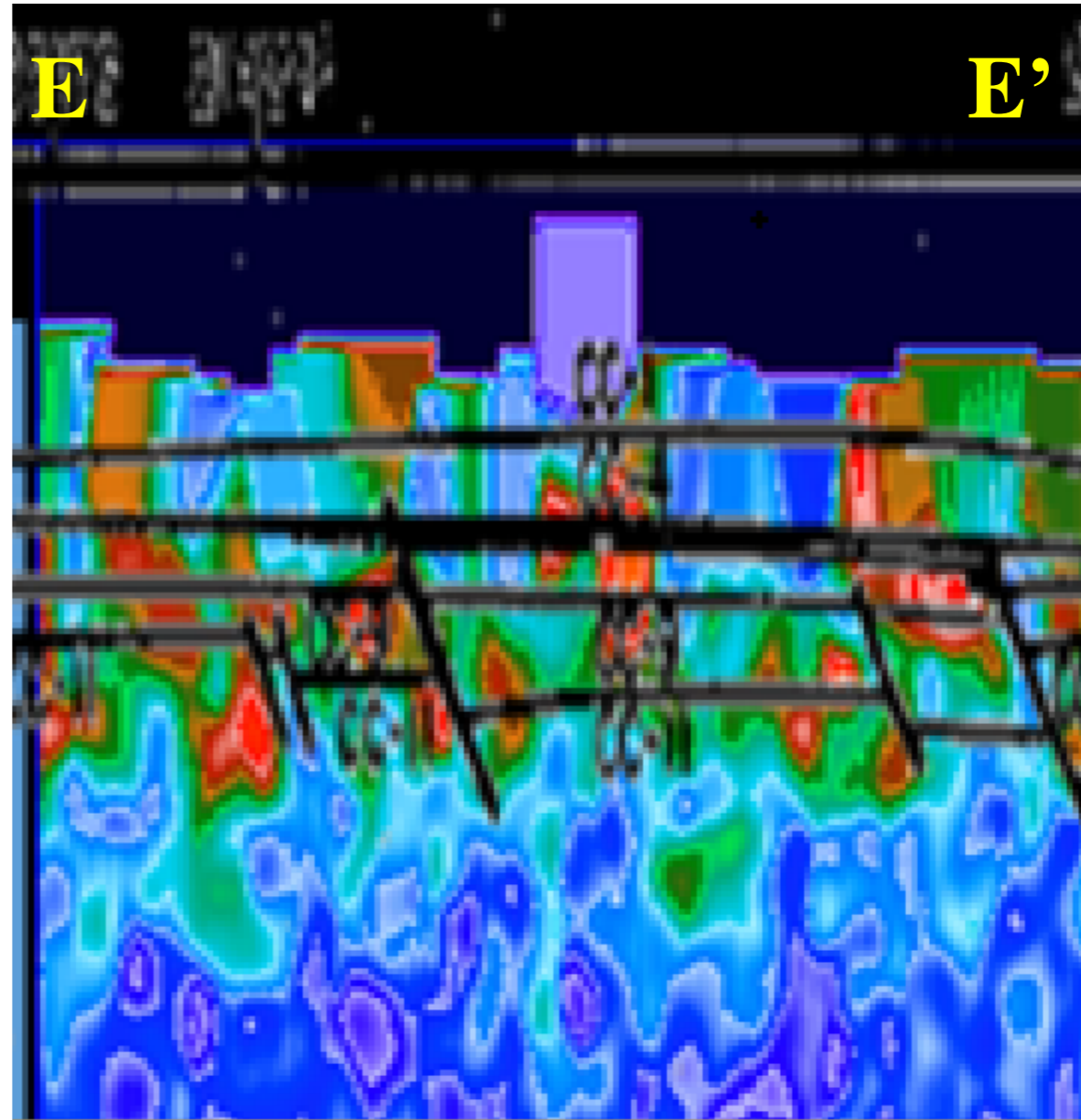





# Apparent-Resistivity extension of Ewing (1986) A-A' through Stratton seismic data

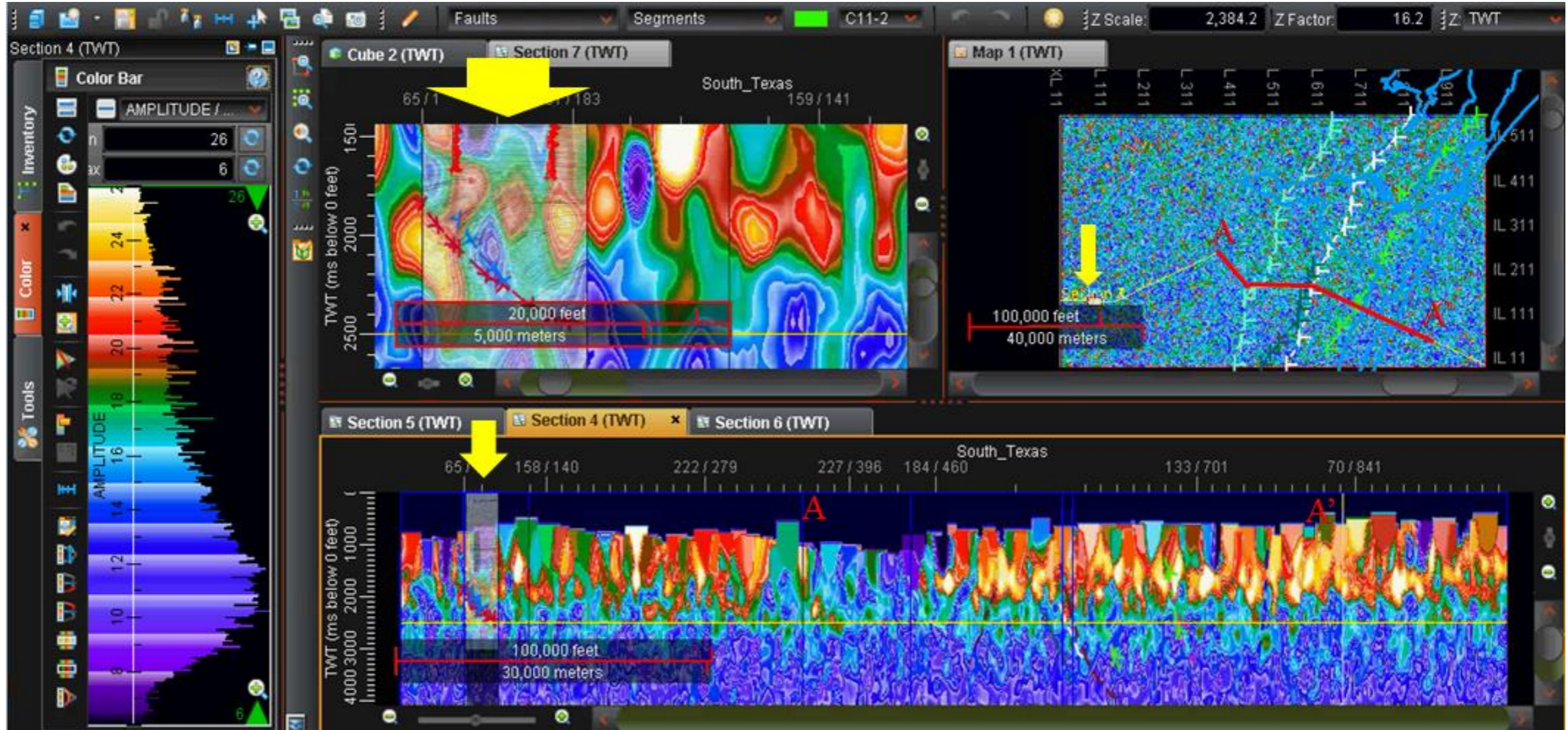

(ohm-meters)





# 2 of 18 Lightning Attributes - Spike

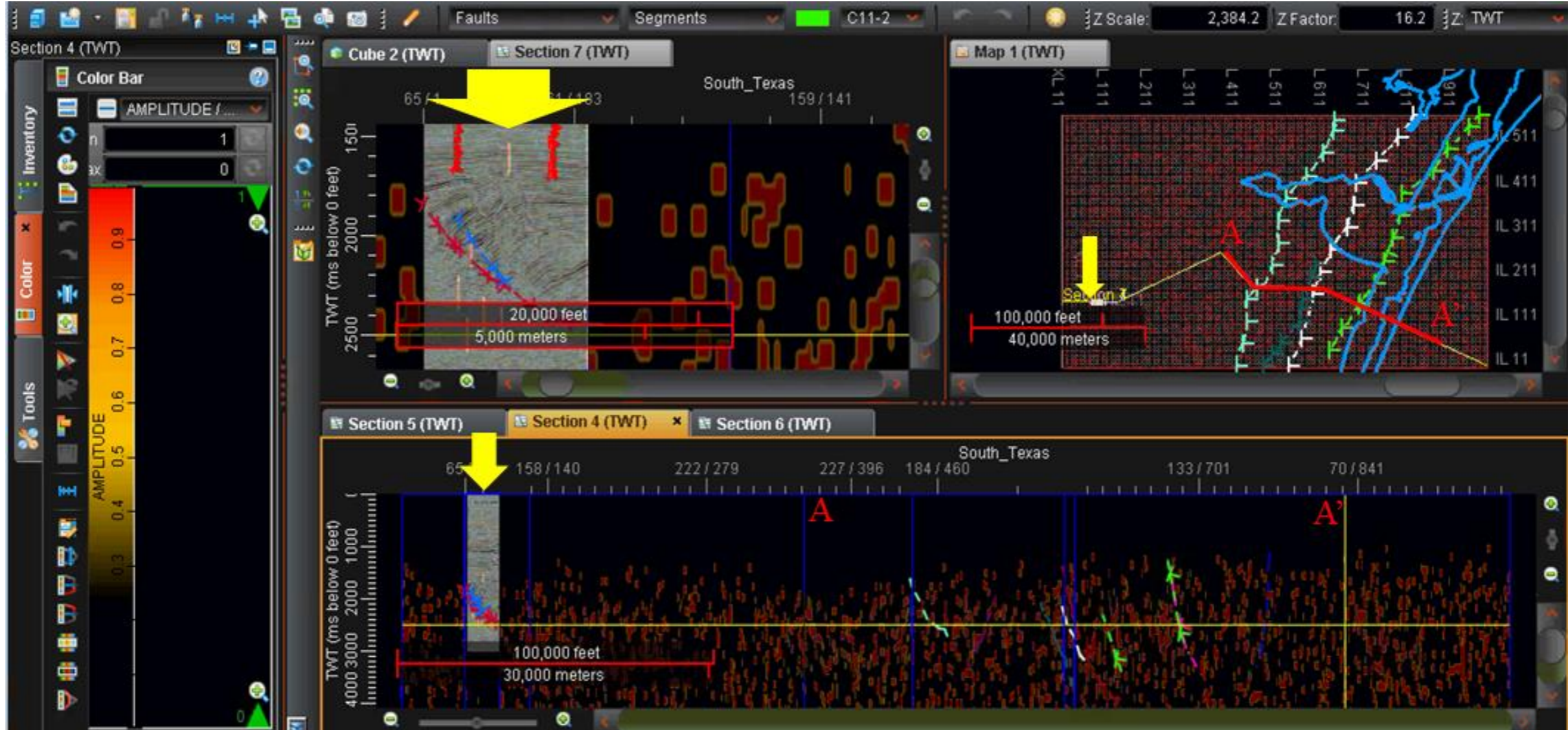





# 3 of 18 Lightning Attributes - Energy

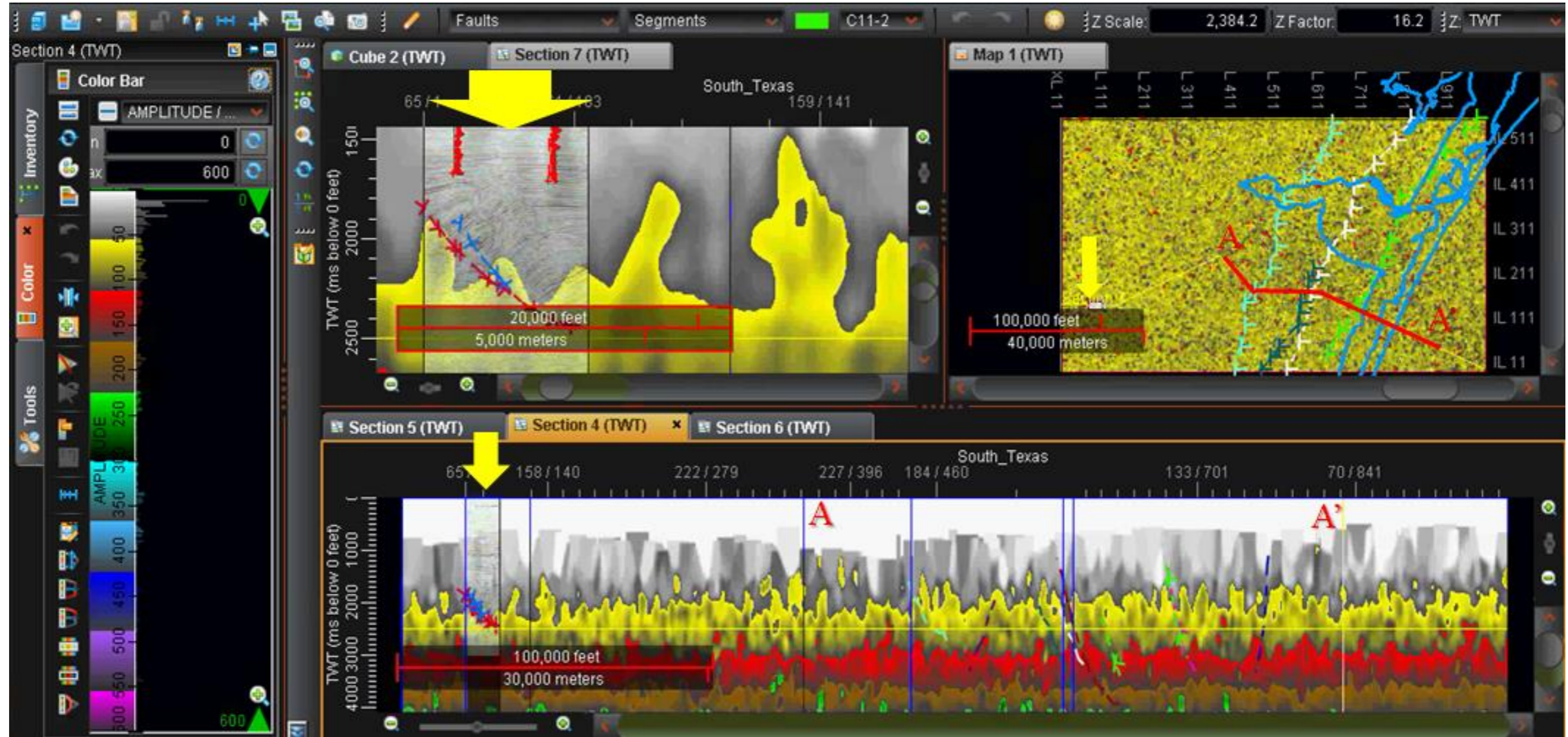





# 4 of 18 Lightning Attributes - Frequency

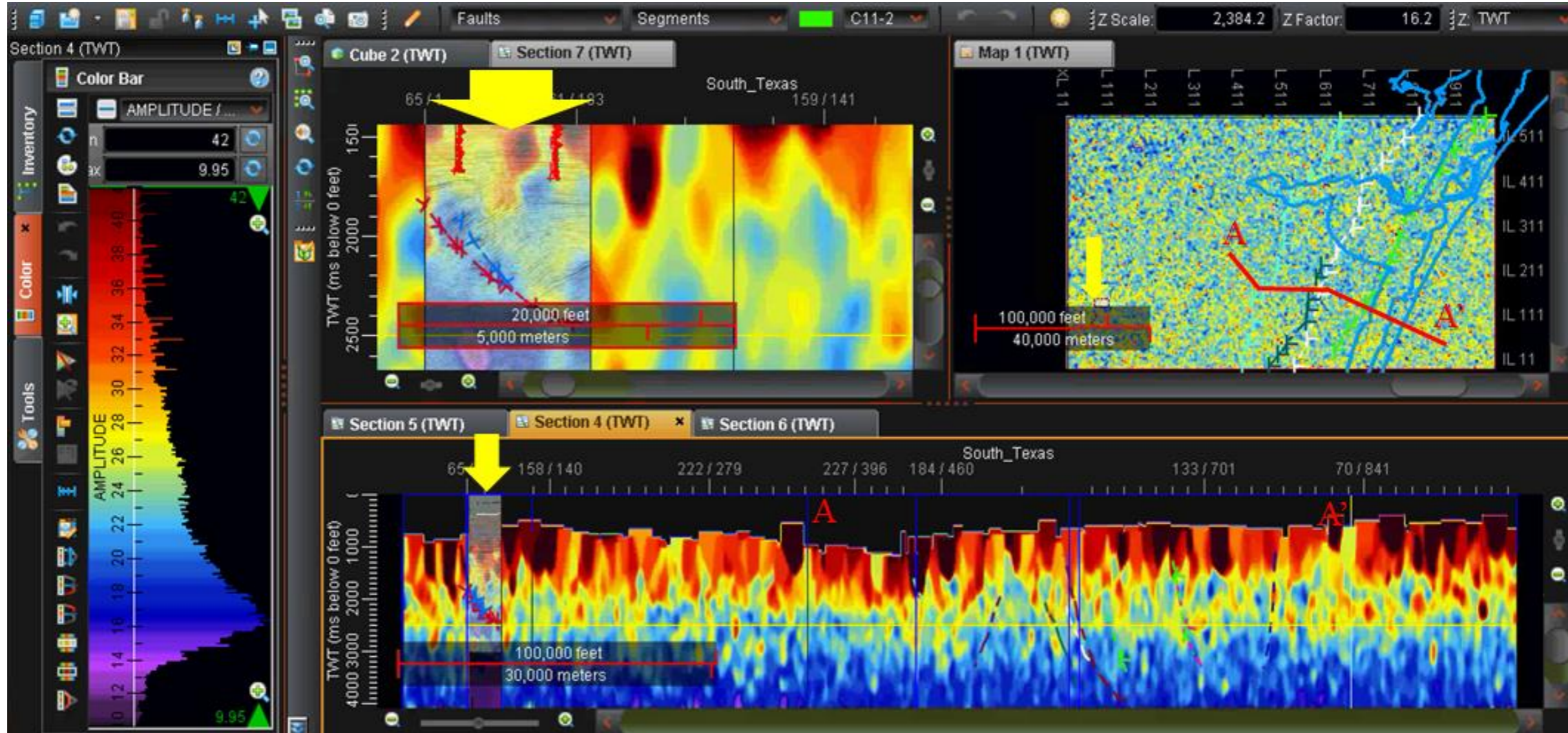

(kilohertz)





# 5 of 18 Lightning Attributes - Moon Local Longitude

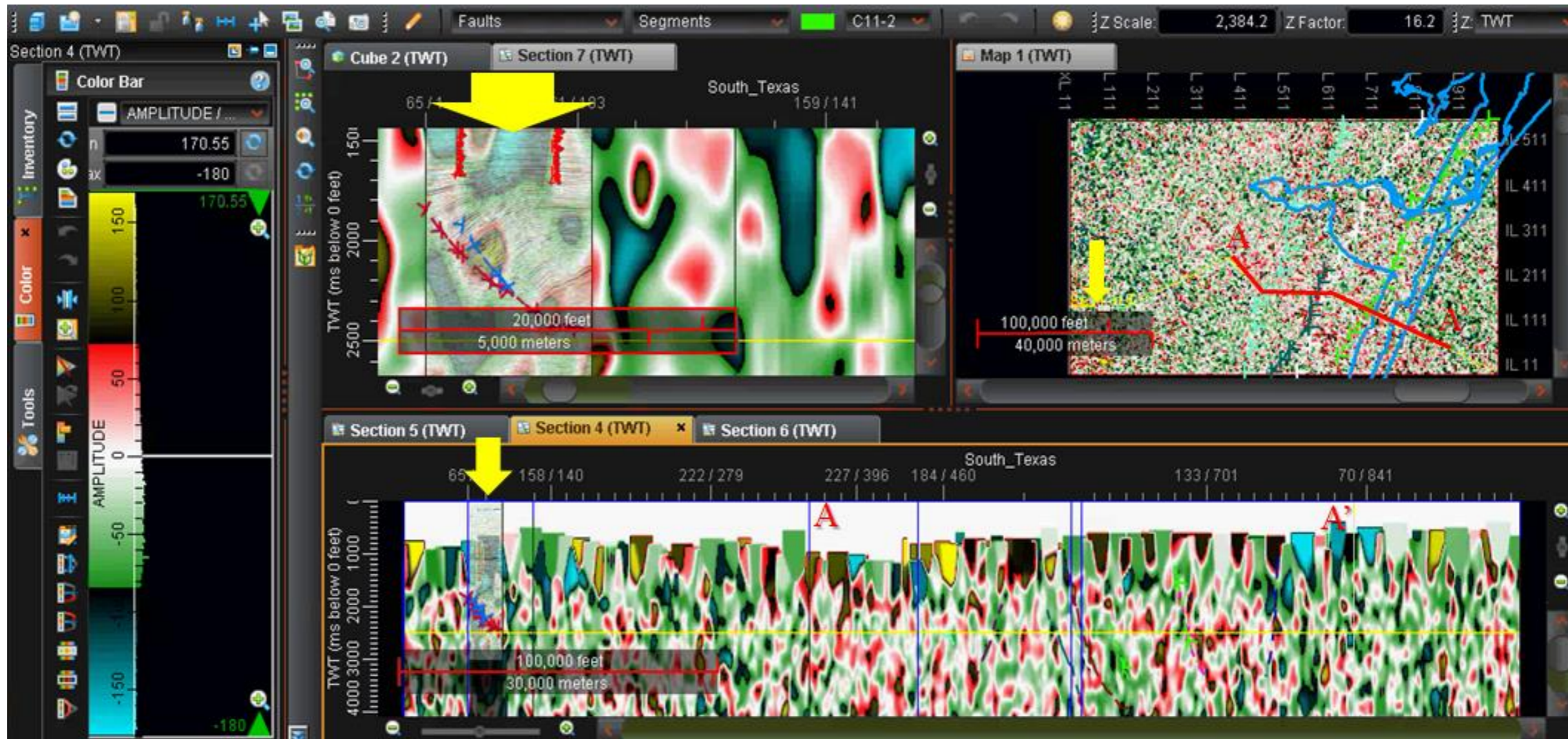





# 6 of 18 Lightning Attributes - Rise Time

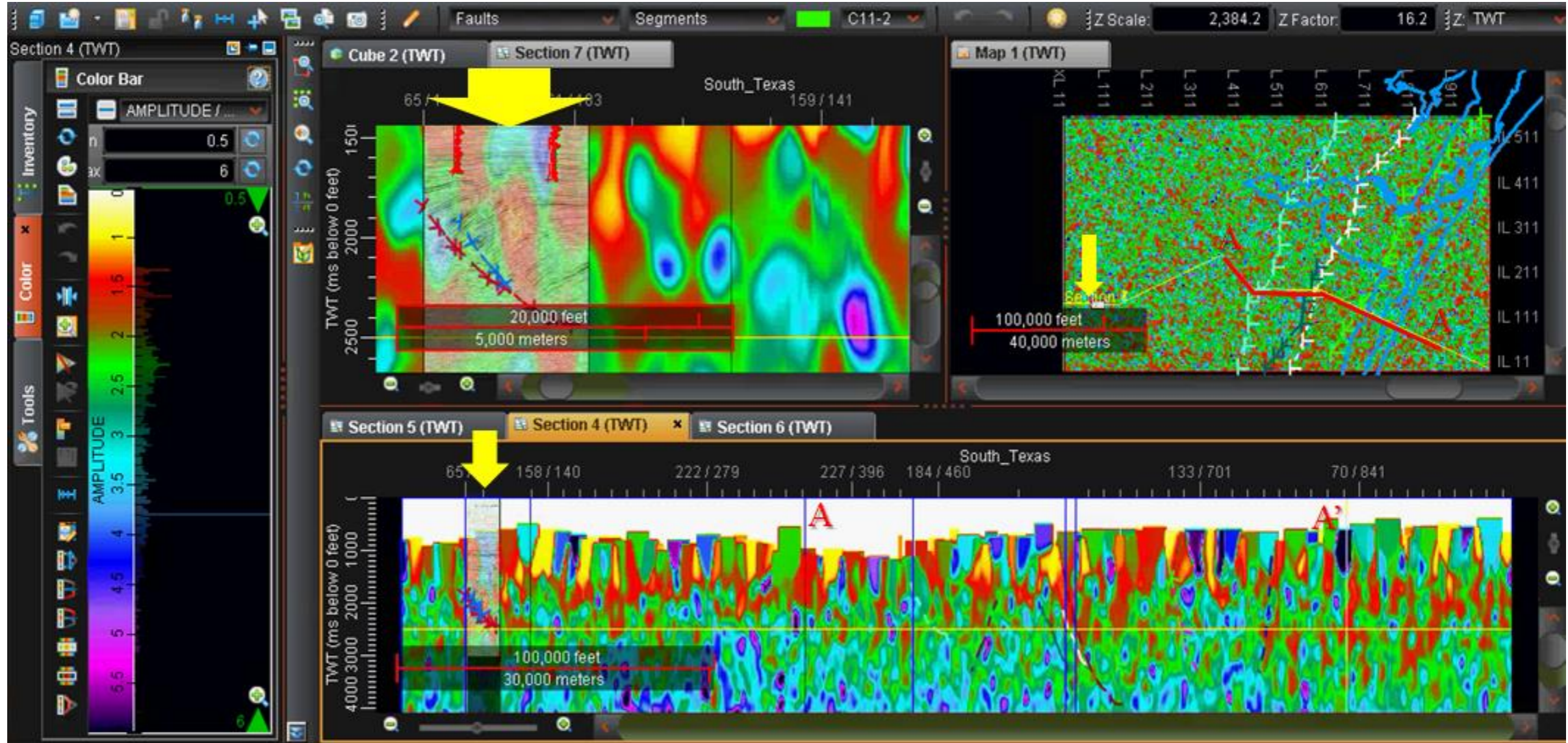





# 7 of 18 Lightning Attributes - Peak Current

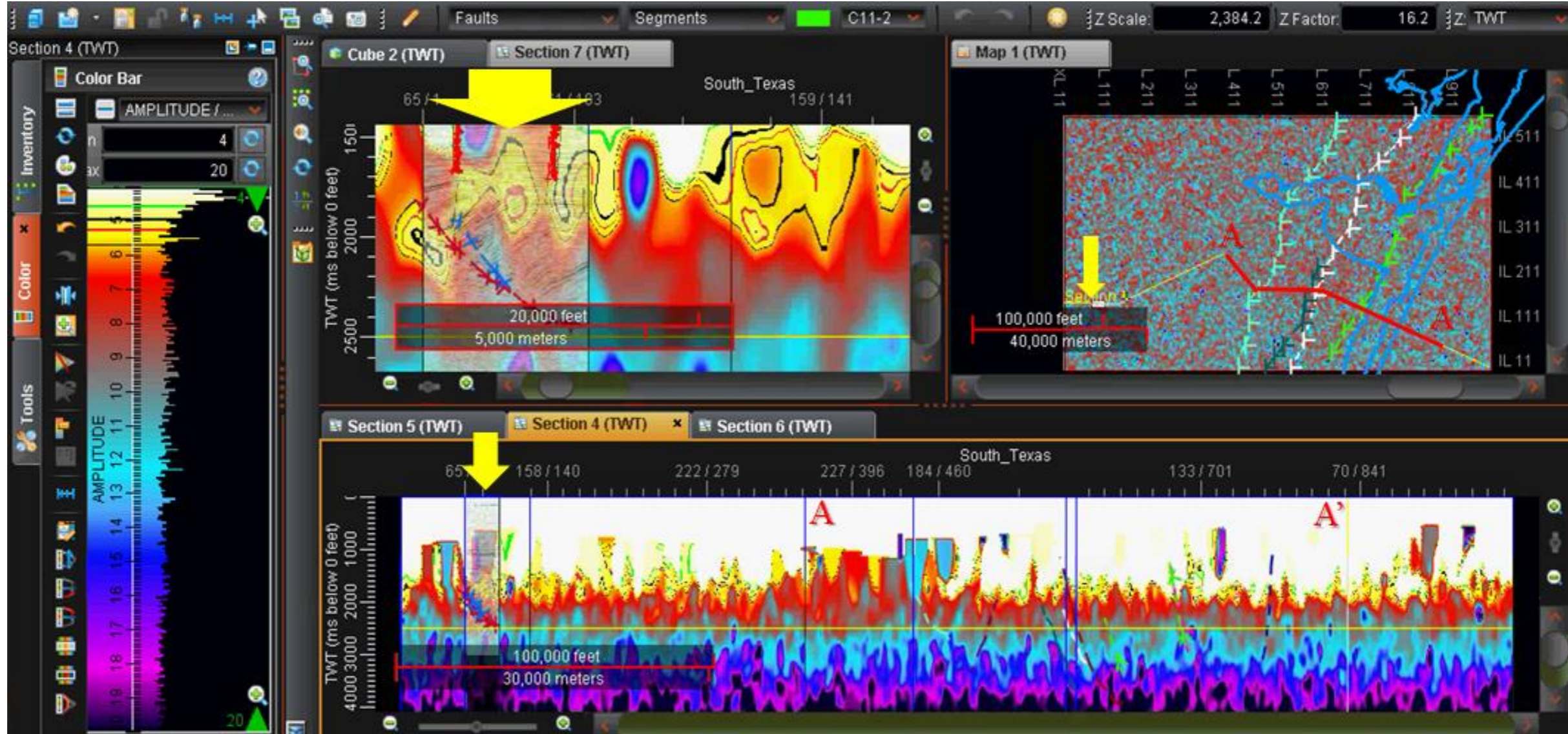

(kiloamperes)





# 8 of 18 Lightning Attributes - Peak to Zero

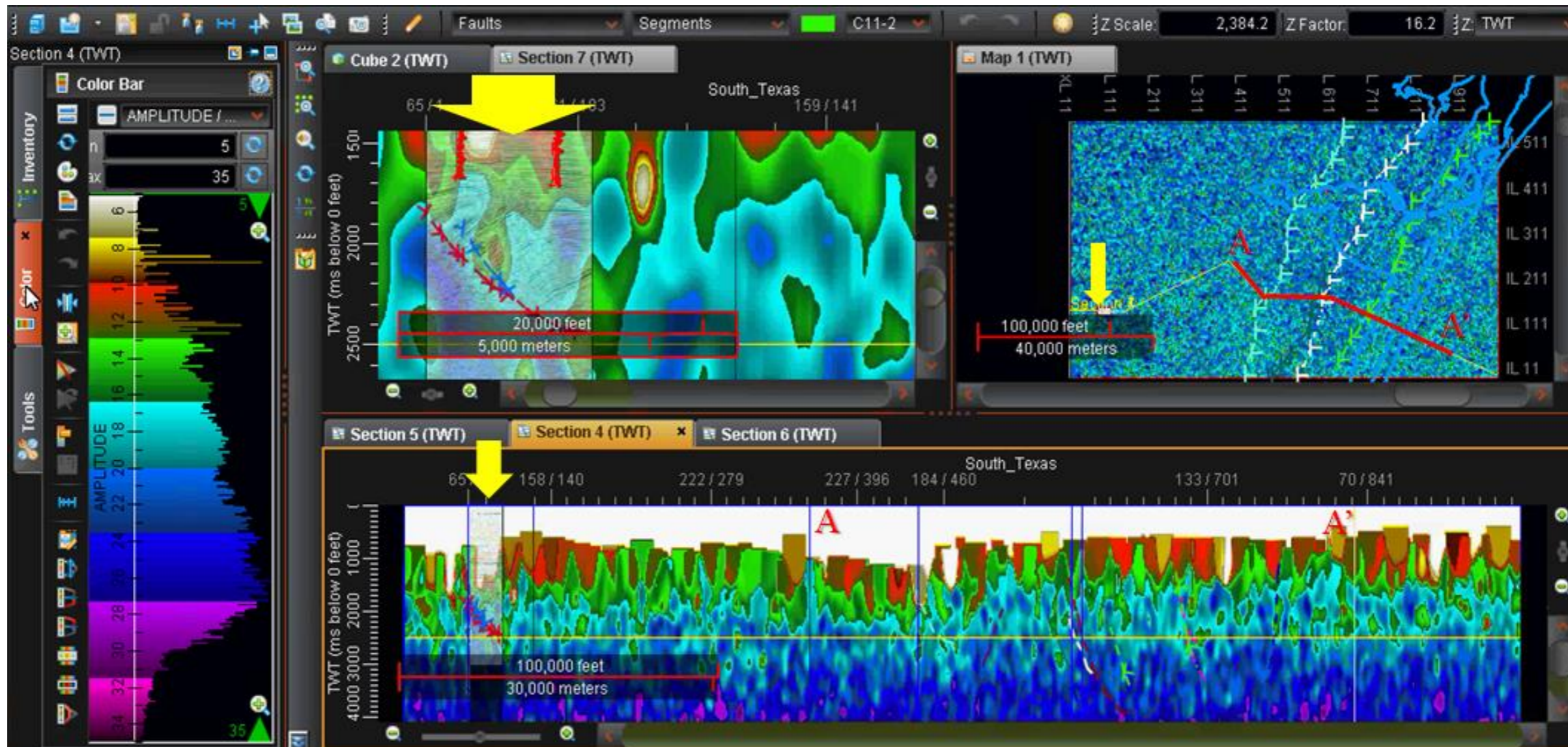

(microseconds)





# 9 of 18 Lightning Attributes - Apparent Permittivity

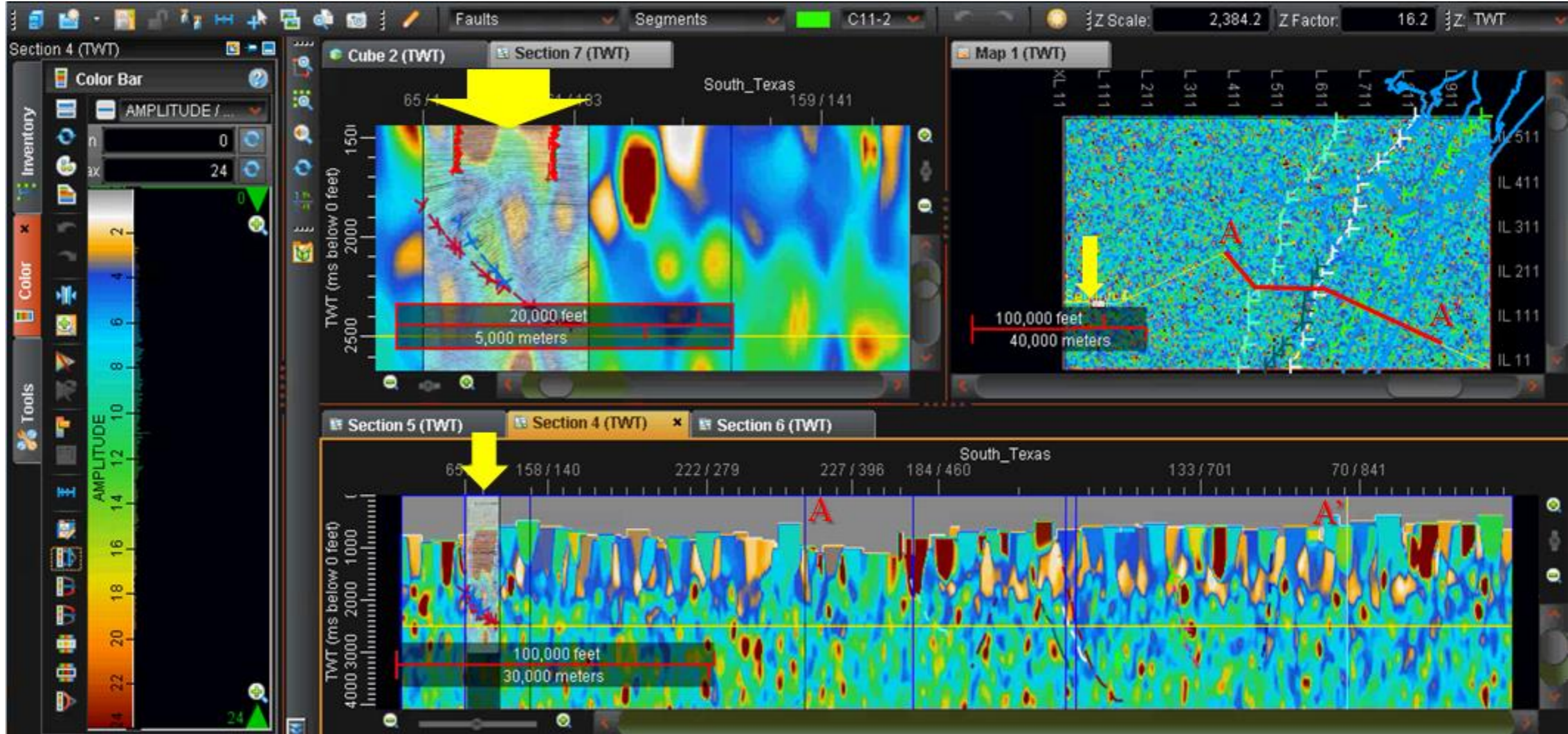

(microfarads per meter)





# 10 of 18 Lightning Attributes - Tide Gradient

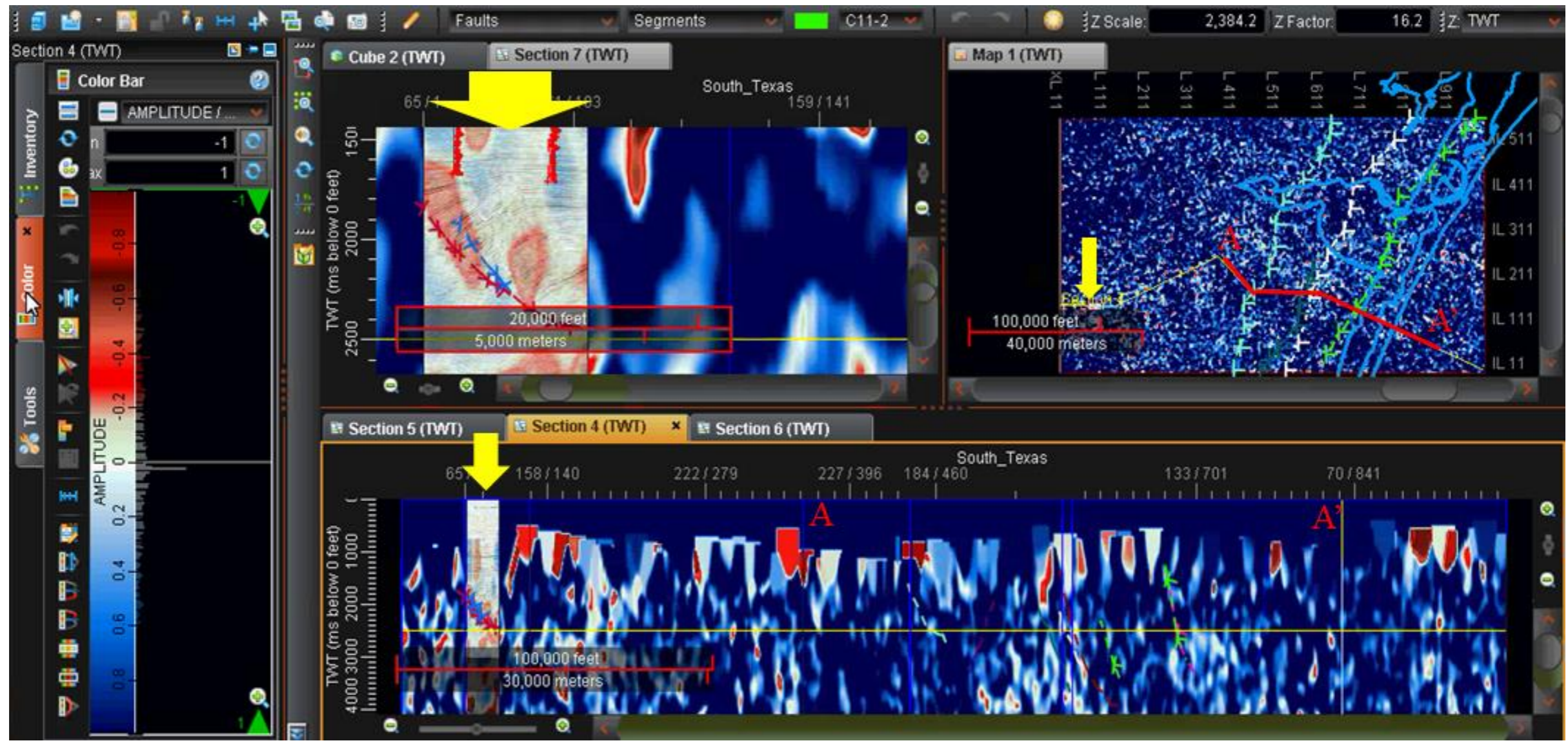



# 5. One Last Texas Example

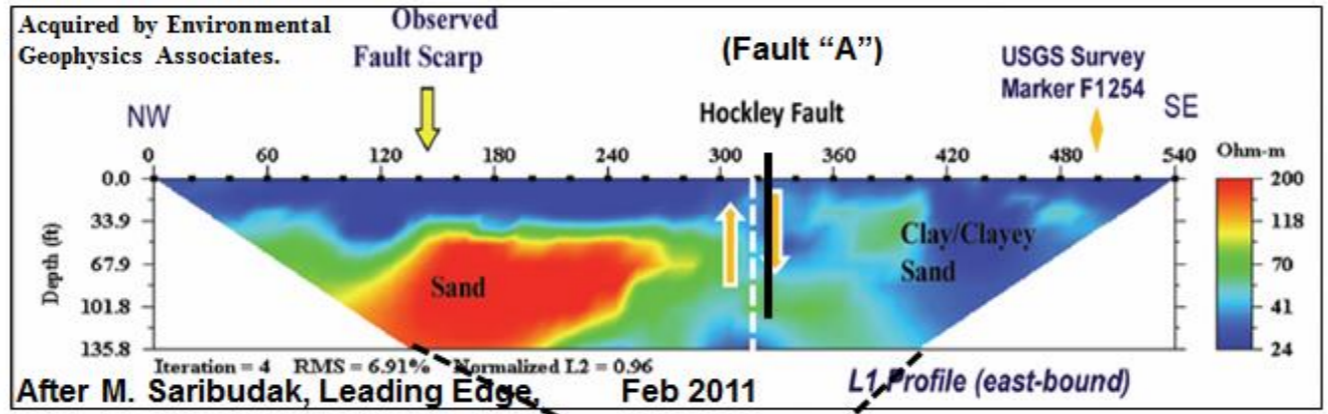

Additional faults suggested.

Are they geologically reasonable, internally consistent, valid?

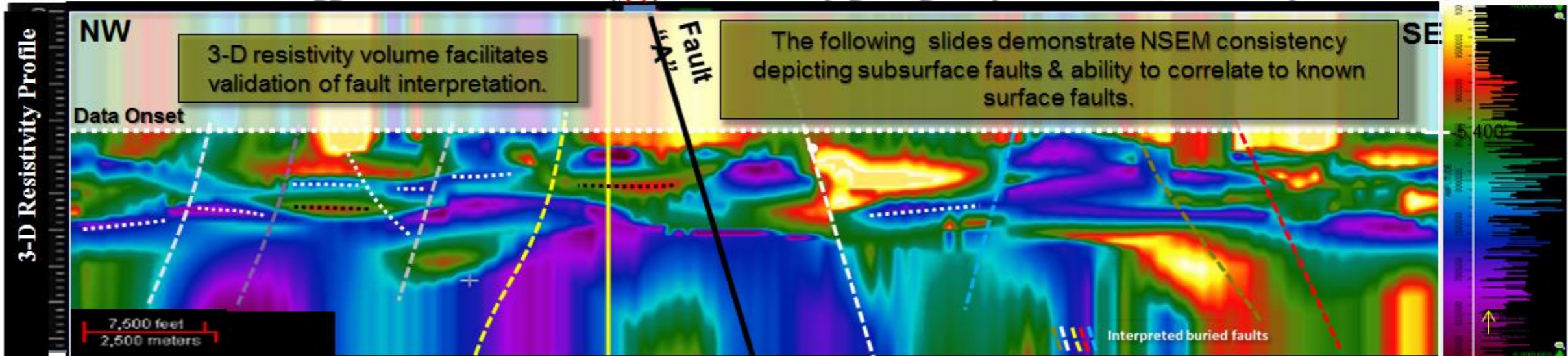

2-D Resistivity Survey ties Lightning-Derived Resistivity Cross-Section





# 5. Steuben County, New York Example

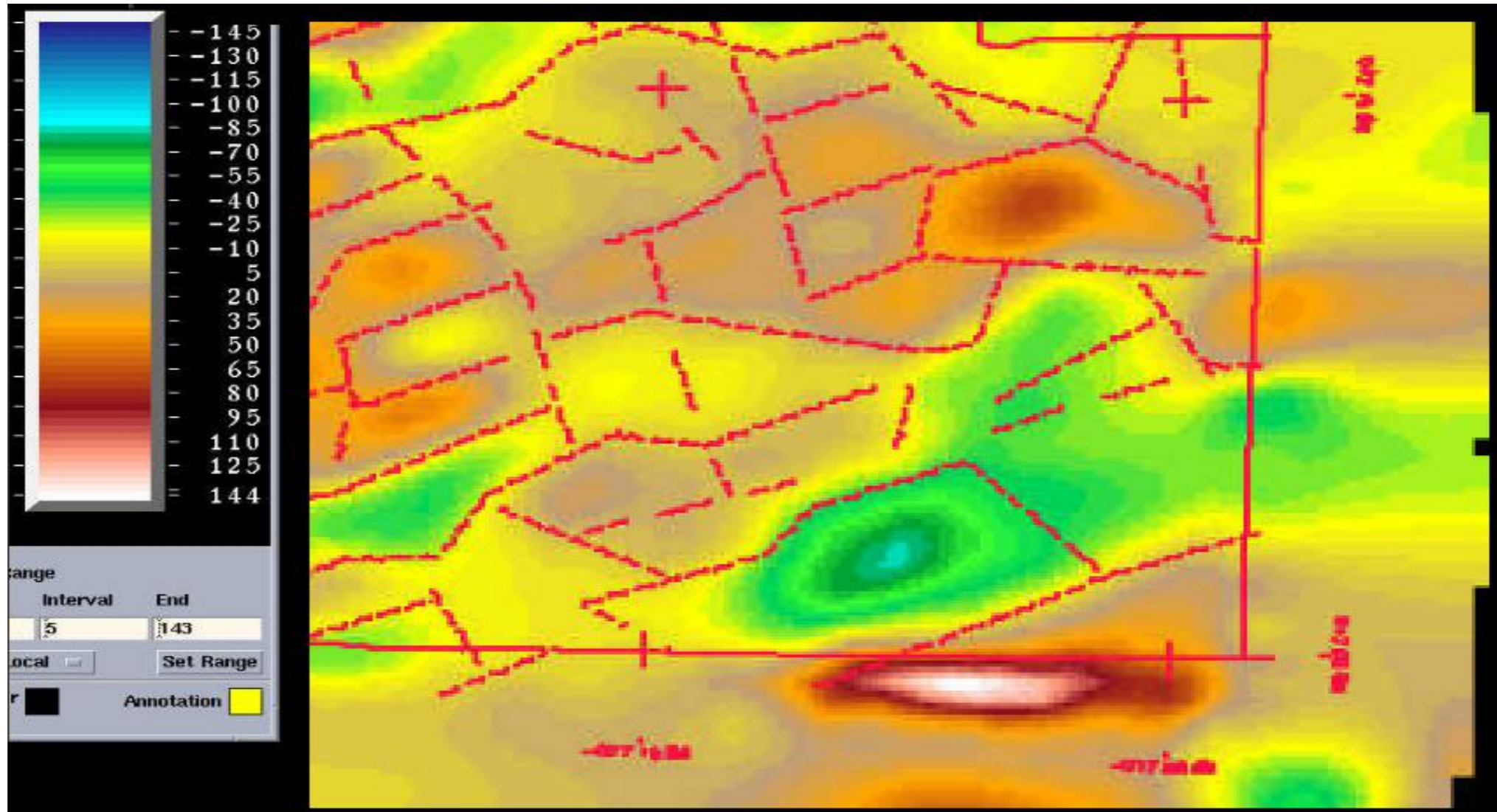

Interpolated NewMag® and Interpretation Overlay

Copyright © 2017  
Dynamic Measurement LLC.





## 5. Steuben County, New York Example continued

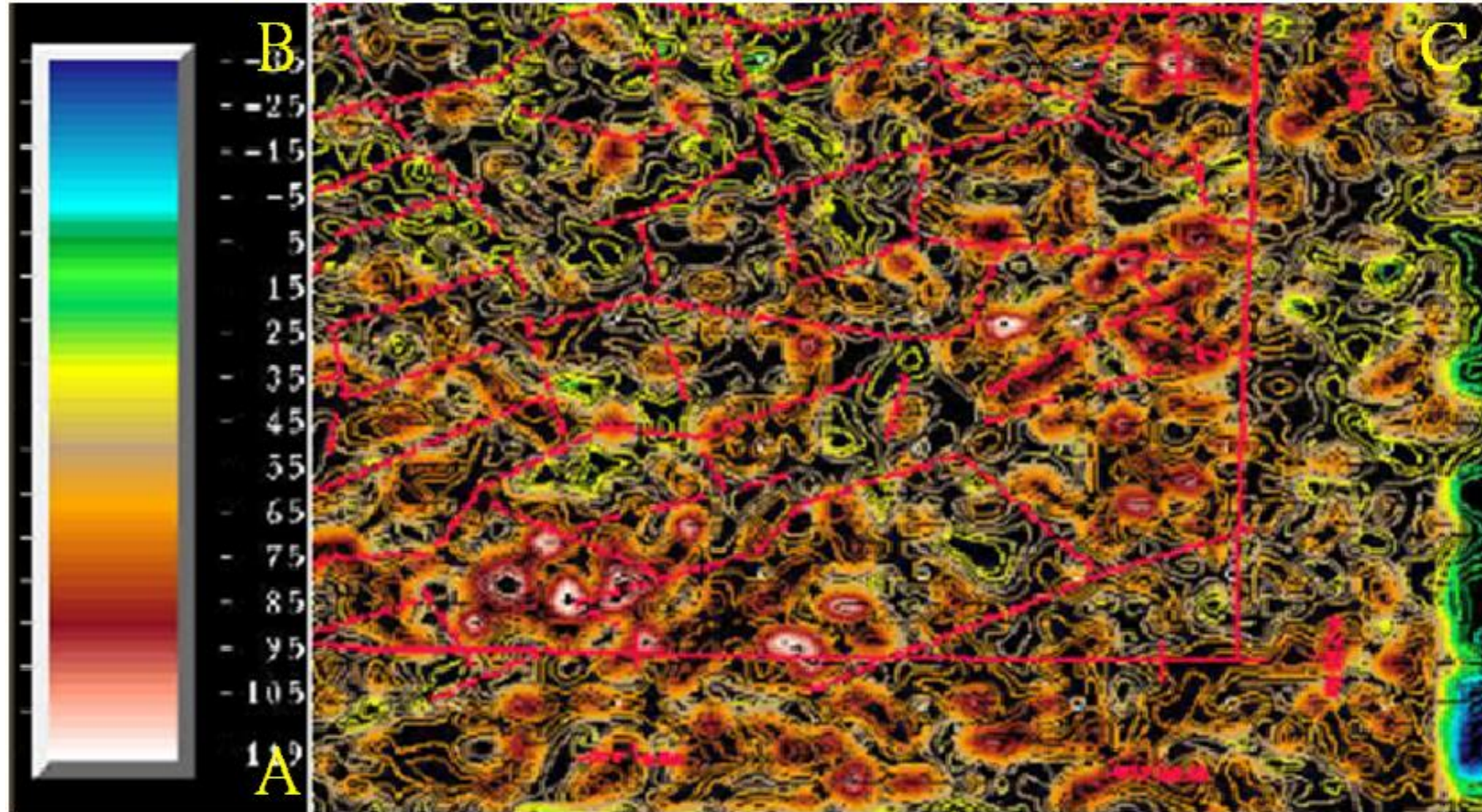

Lightning Density Map and NewMag® Interpretation





# 5. Louisiana Example – salt domes

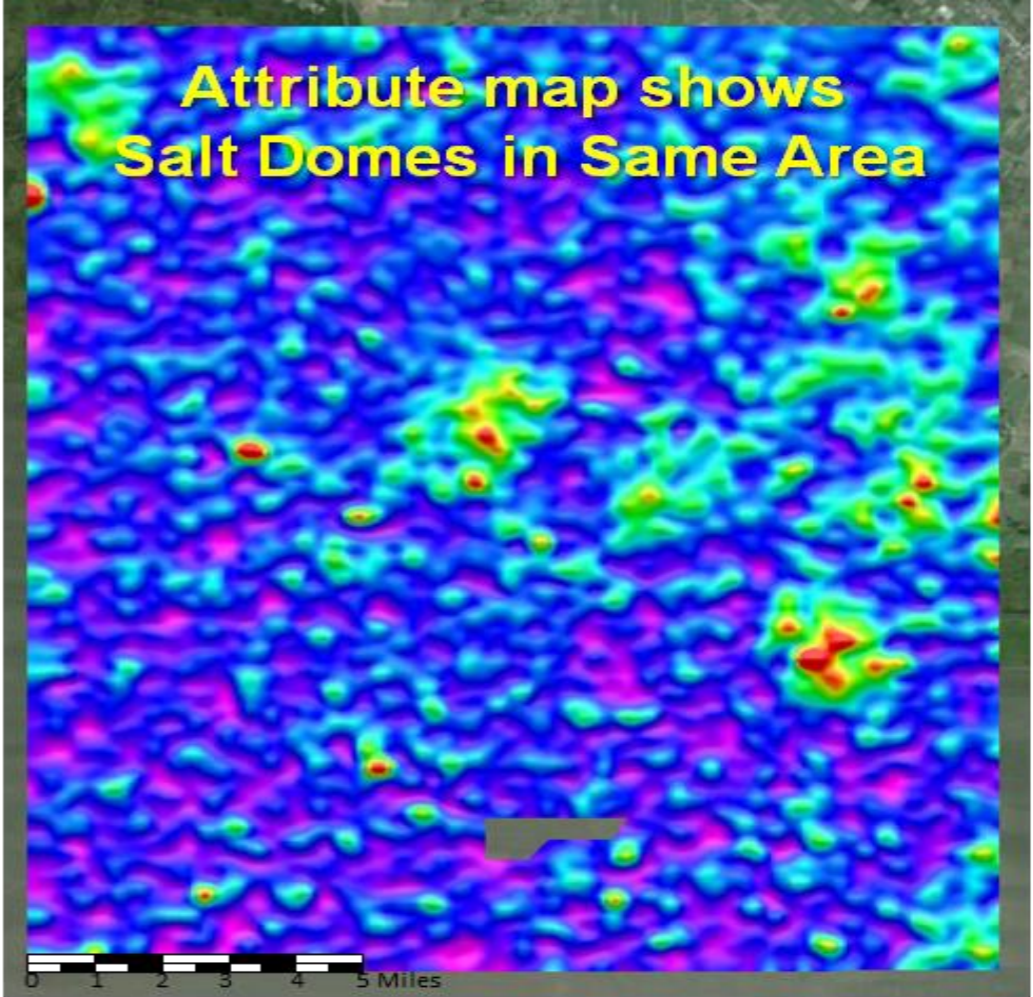
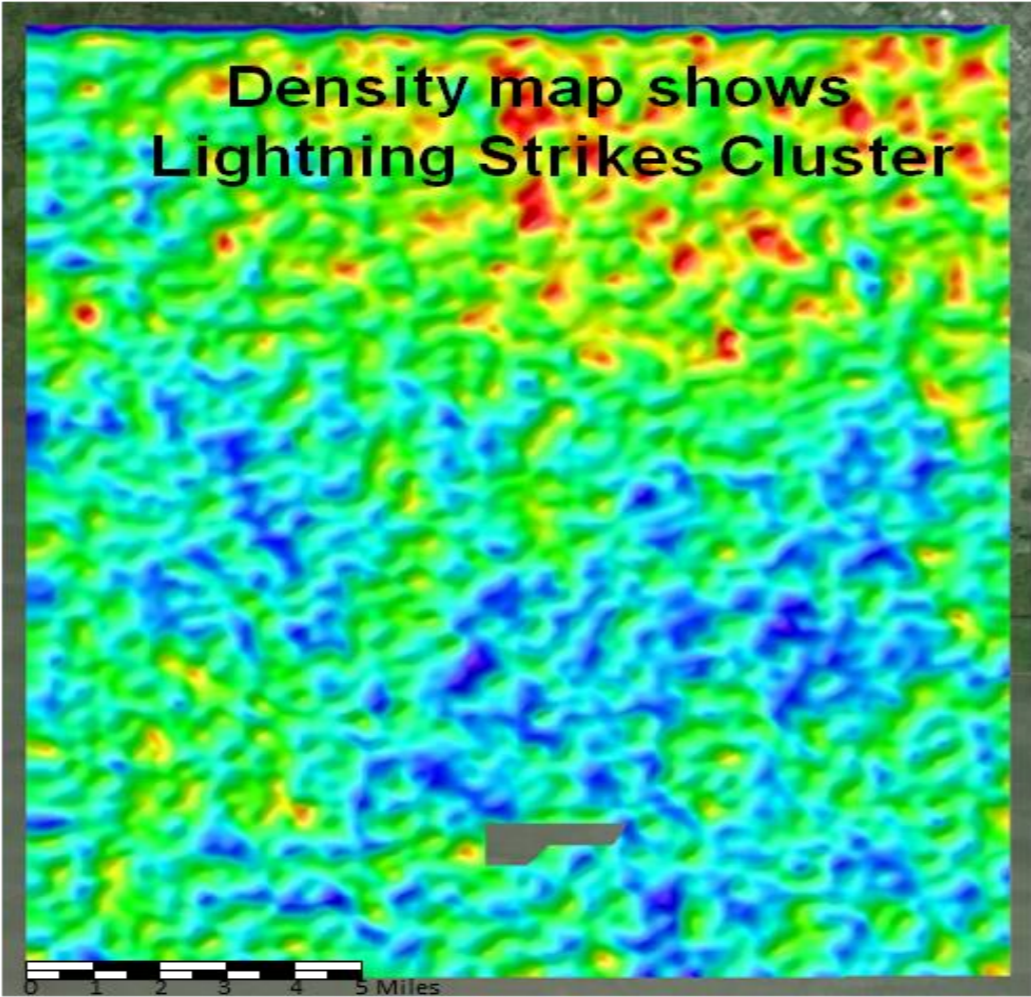

Density Map

& Rate-of-Rise-Time Map





# 5. Arizona Example: Resolution Copper



### NLDN Peak Current

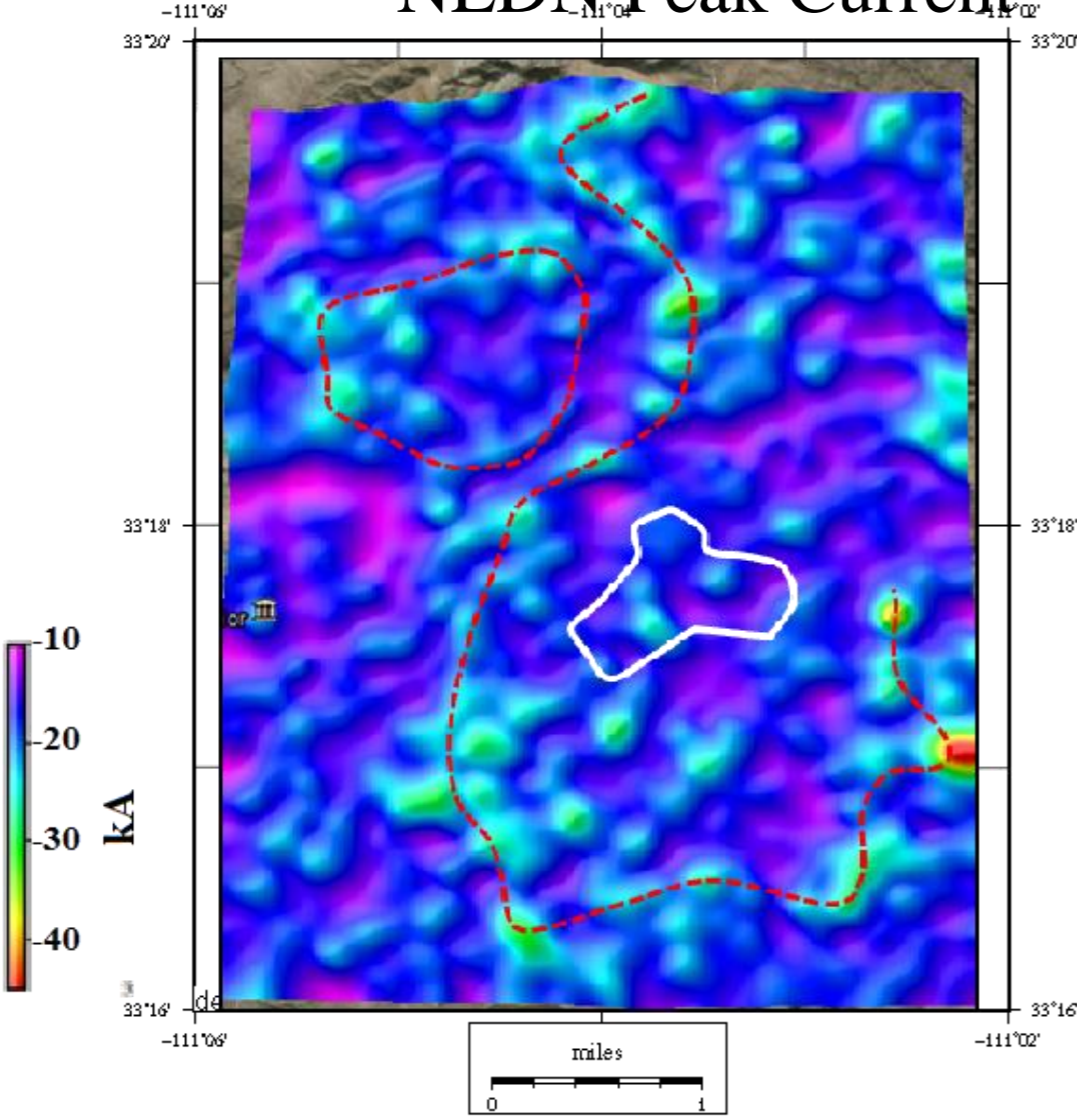

### & Rise-Rate

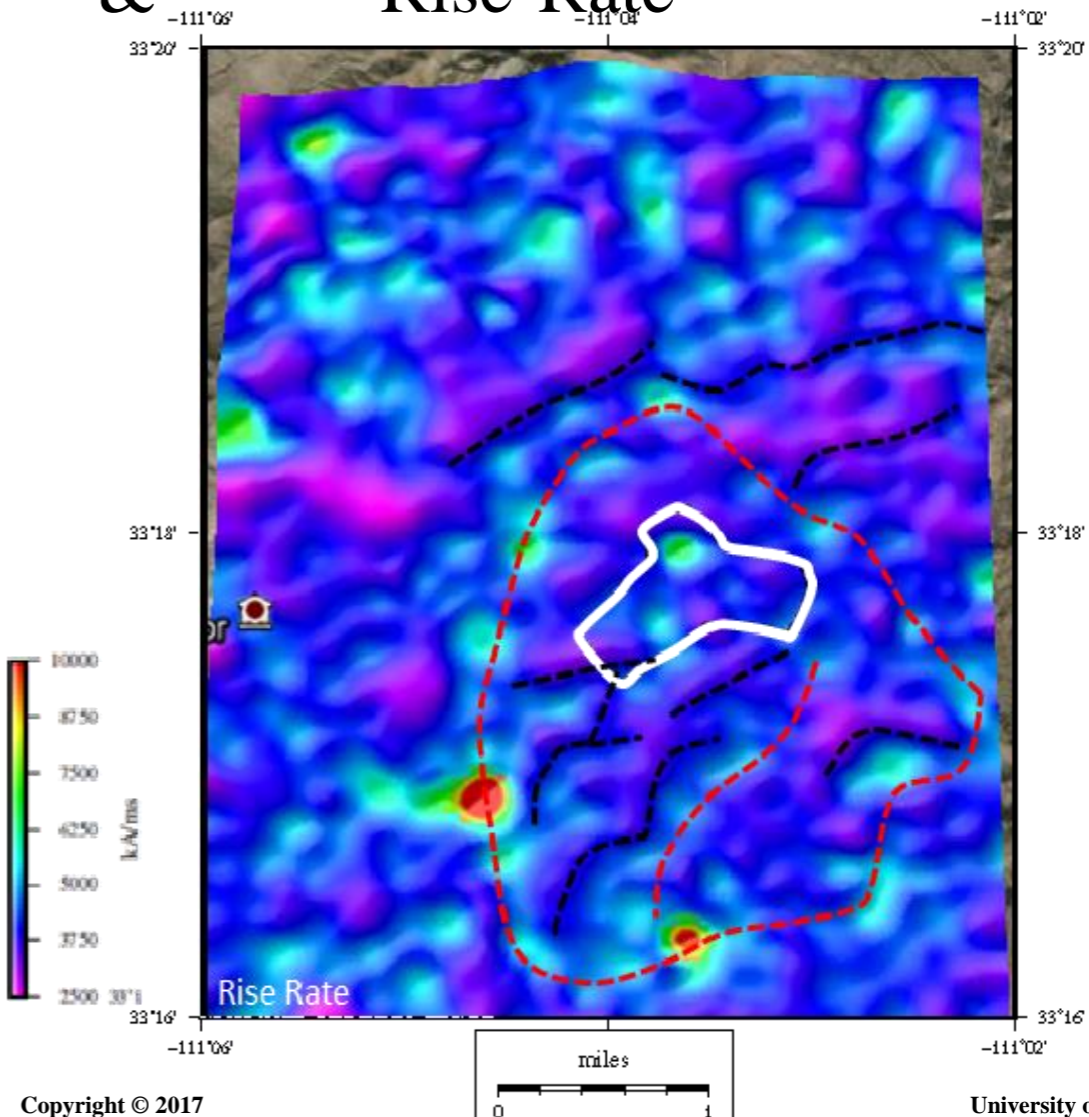

Copyright © 2017  
Dynamic Measurement LLC.





# 3 Example SPOT<sup>SM</sup> Apparent-Resistivity Cylinders

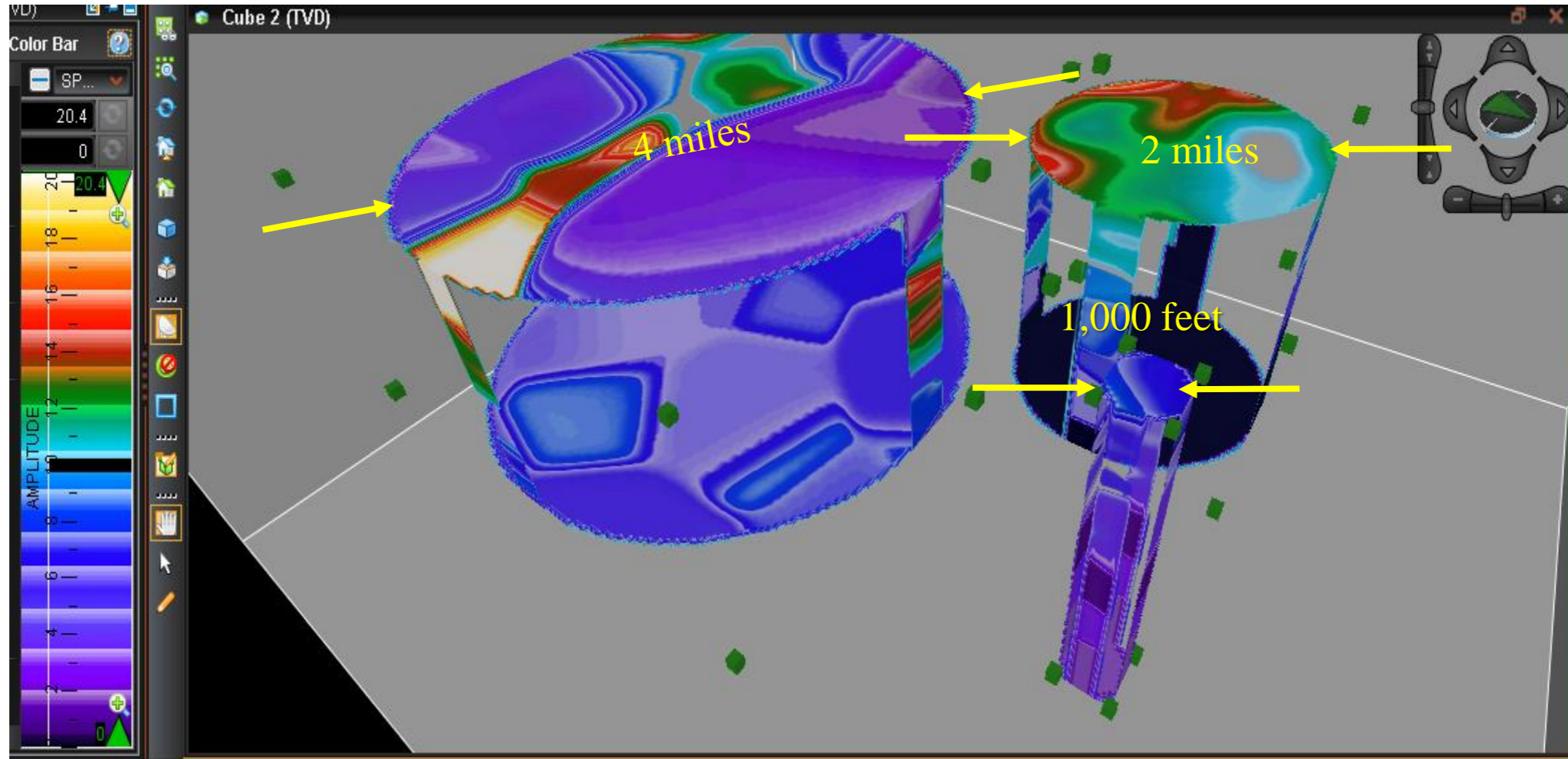





# Integrating Resistivity in Three-Dimensions

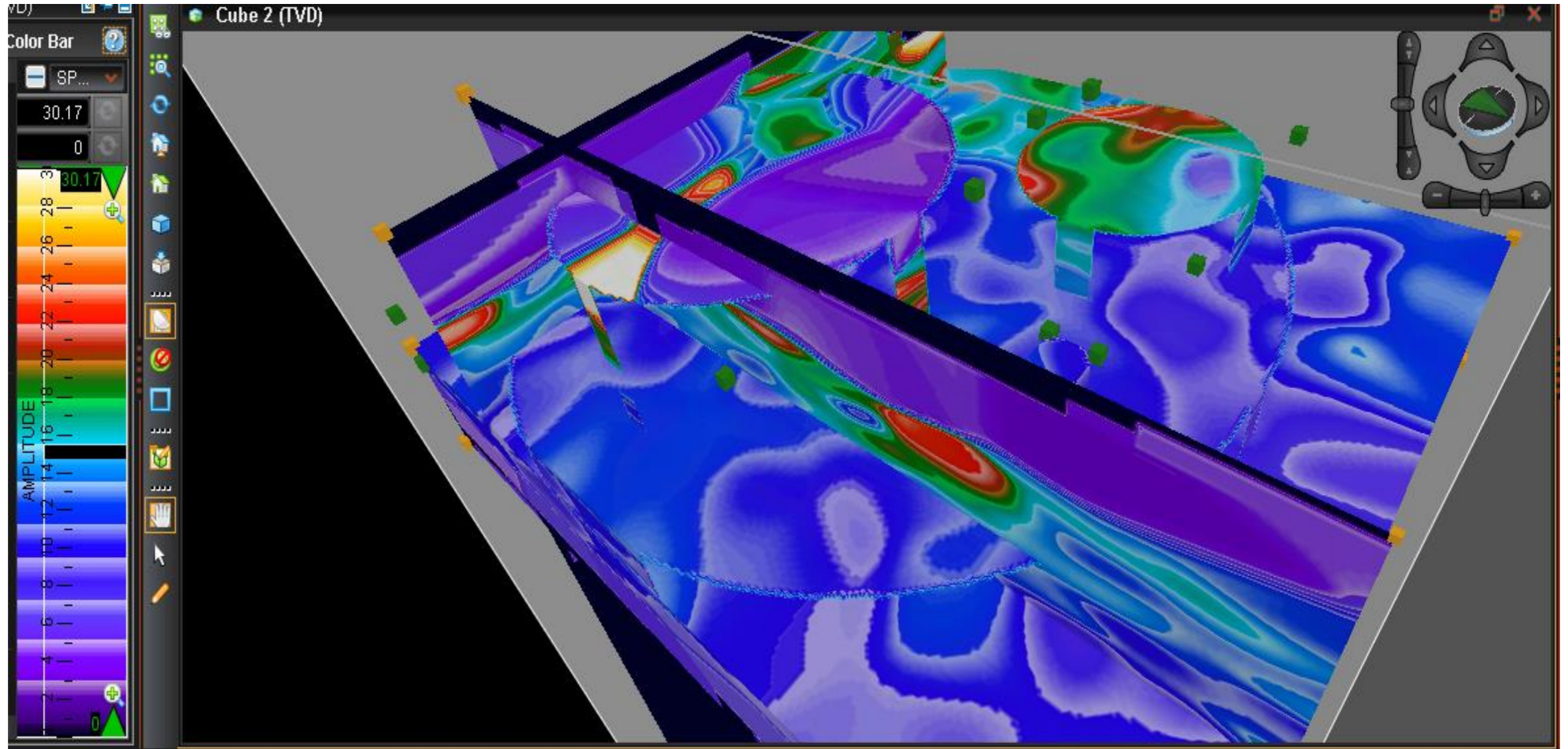





# Comparing NLDN and GLD-360



## NLDN Density 1998-2015 & GLD-360 Density 2012-2015

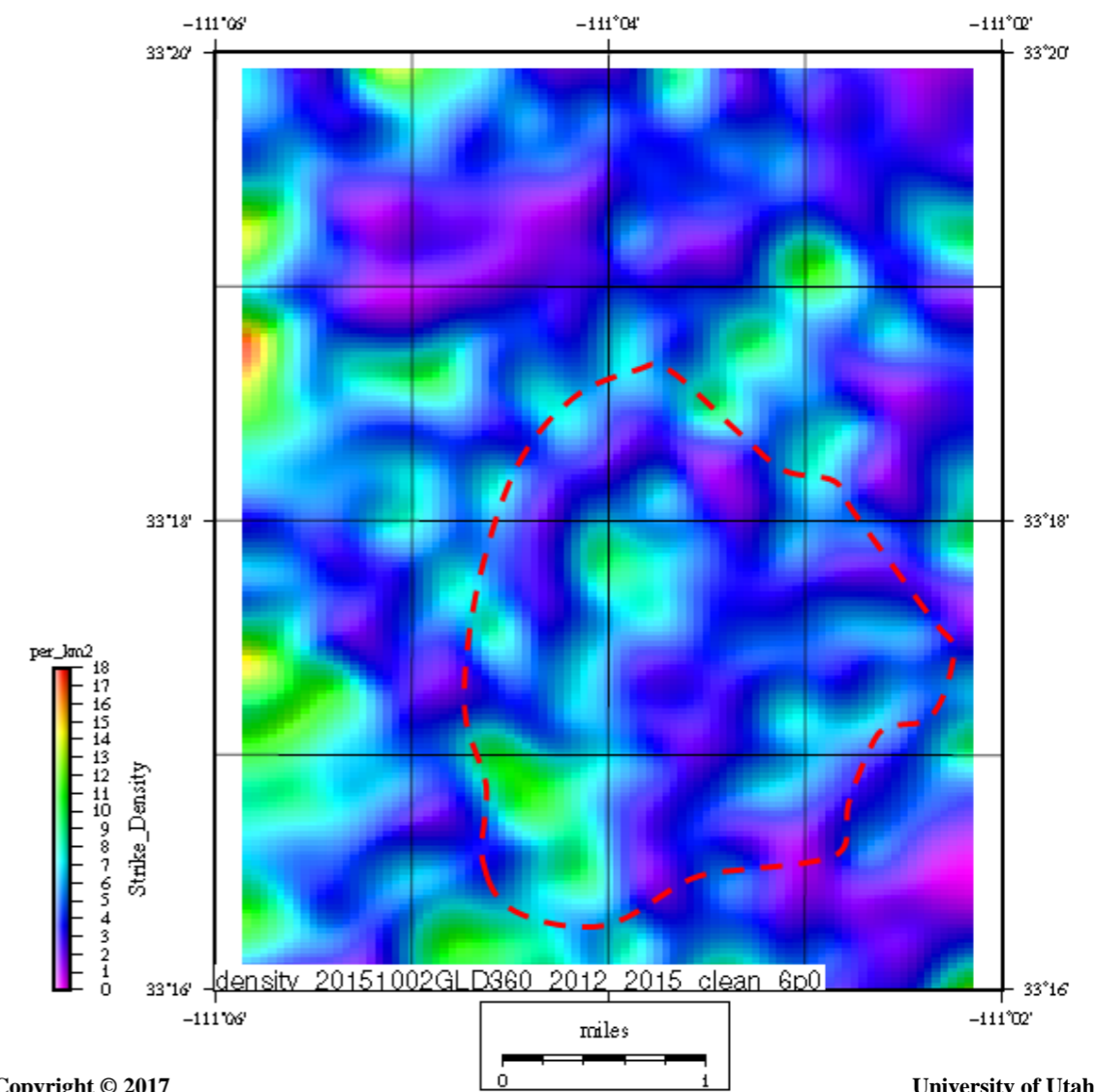
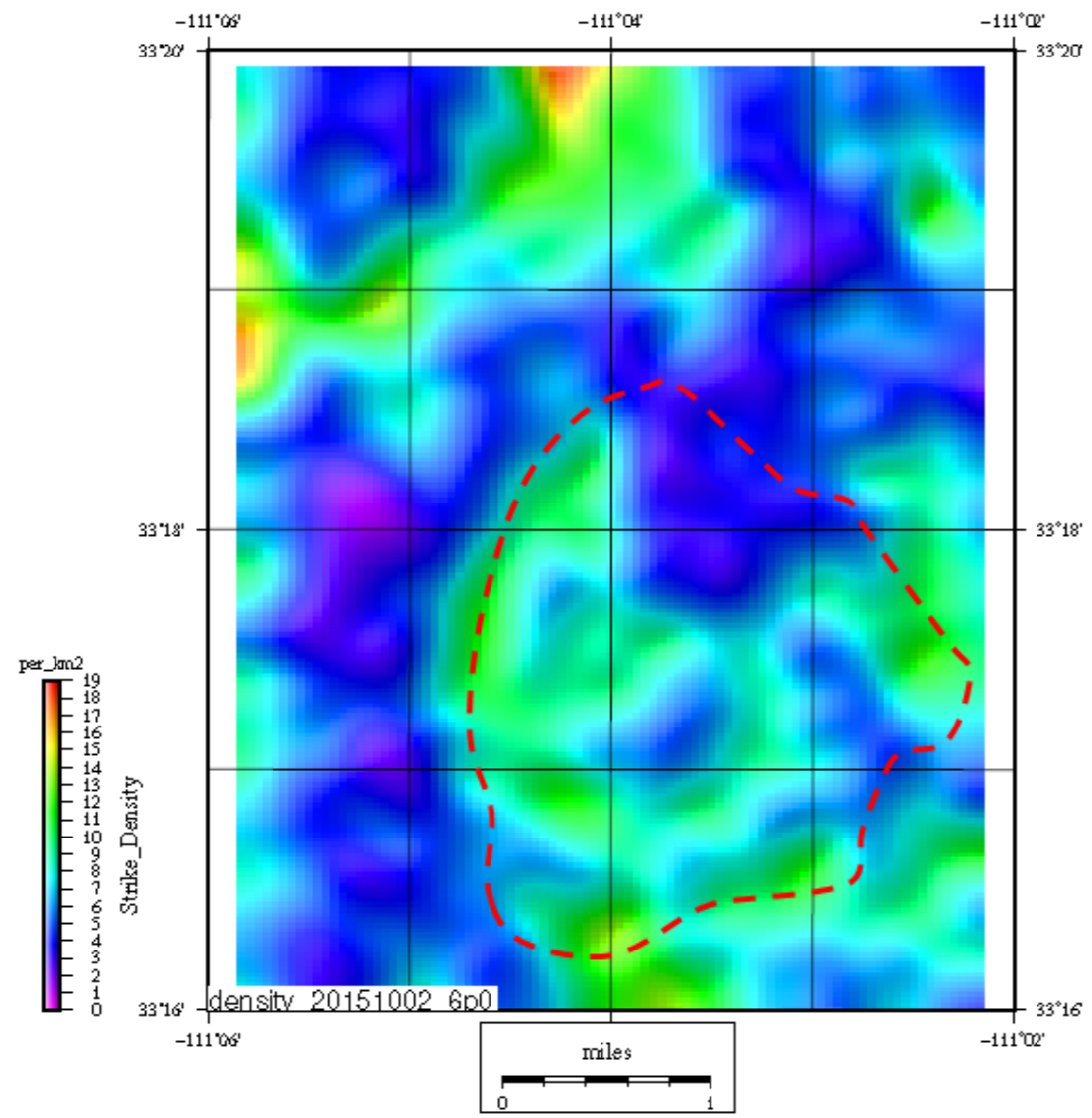





# Resolution Copper Cross-Plots

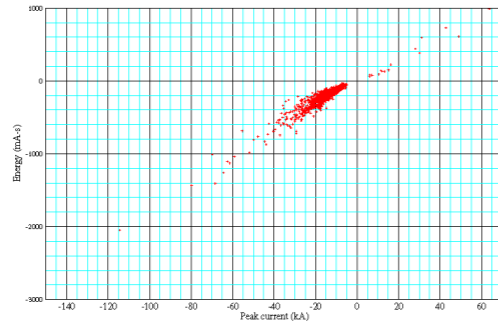

Figure 6: Peak current vs energy

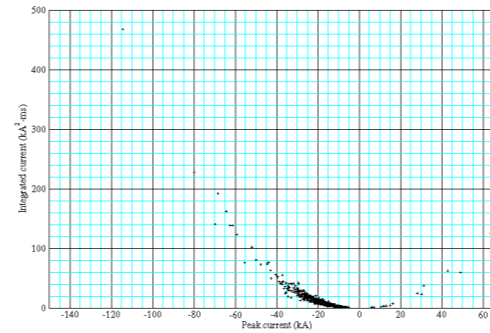

Figure 13: Peak current vs resistivity

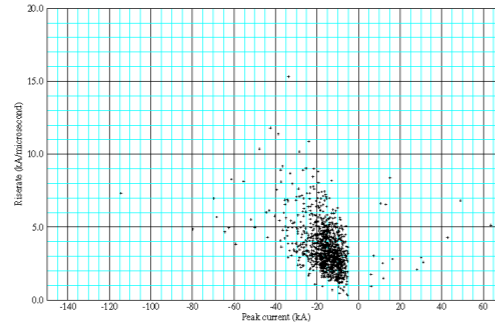

Figure 14: Peak current vs riserate

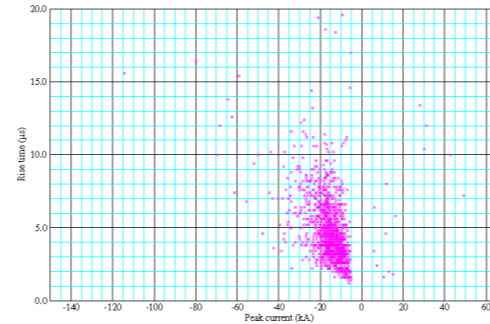

Figure 15: Peak current vs risetime

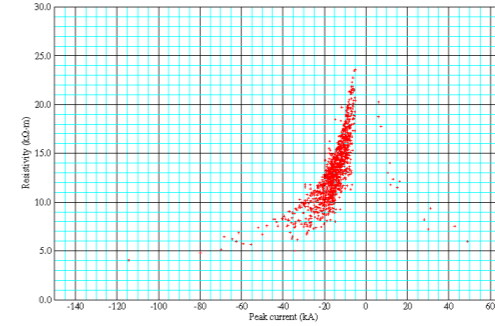

Figure 1: Peak current vs strike density

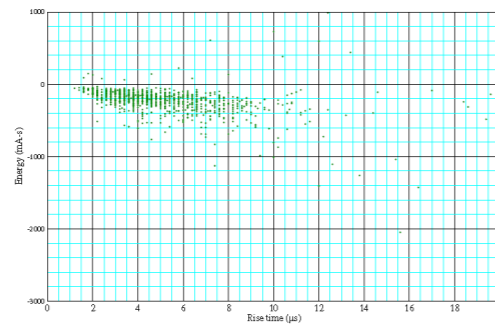

Figure 28: Rise time vs energy

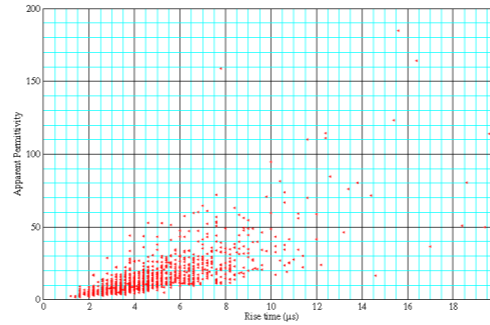

Figure 34: Rise time vs permittivity

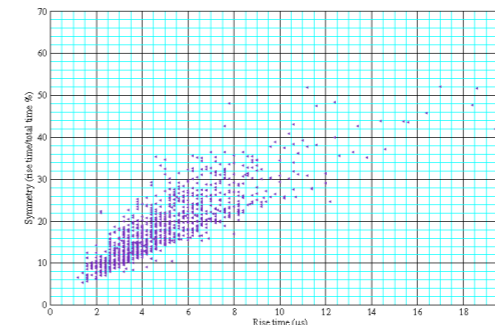

Figure 38: Rise time vs symmetry

03 March 2017

Copyright © 2017  
Dynamic Measurement LLC.

University of Utah 56





# Interns at Dynamic Measurement

**Well received similar presentation at BYU & SMU  
Dynamic is a start-up with only non-paid Interns**

## Intern Contributions:

- J. D. Shumway (BYU, graduated): liked the flexibility, represented Dynamic in our booths at 2015 AAPG in Denver, 2015 GCAGS in Houston, and fall 2016 DHI Consortium.
- Dustin Northrup (BYU): co-author on article submitted to The Leading Edge (being reworked) and paper submitted to 2017 AAPG
- Corbin Lewis (BYU): co-author on article submitted to The Leading Edge (being reworked) and paper submitted to 2017 AAPG
- Tucker Zukowski (SMU): exploring opportunities, looking at tying heat flow study to California gold exploration project

J.D., Dustin, and Corbin each have lightning analysis projects they have worked on where they used Landmark's DecisionSpace™ software to interpret lightning analysis projects





## Summary

- Dynamic Measurement has made a lot of progress in understanding lightning data analysis since last presenting at the U, 2 1/3<sup>rd</sup> years ago.
- Dynamic has demonstrated the ability to map faults, and to create geo-frameworks in a variety of geological environments.
- As with the development of any new geophysical data type, there is much more to be discovered about approach strengths and weaknesses.
- There is an opportunity to develop the mathematics to (see Appendix):
  - correct for topography and remove topographic distortions;
  - define the electromagnetic fields around a lightning stroke path;
  - optimally stacking and interpolating lightning derived volumes using kriging;
  - model the telluric electrical fields controlling lightning strike locations; and
  - many other basics tied to this new geophysical data type.
- Dynamic is interested in providing interesting projects for Interns.





## Acknowledgements:

- Les Denham, DML Chief Geophysicist.
- Kathy Haggar, DML Geologist.
- Louie Berent, DML Geophysicist.
- BYU Interns Dustin Northrop and R. Corbin Lewis.
- Tom Ewing (BEG) for regional South Texas geology.
- Bob Hardage & Ray Levy (BEG) for Stratton seismic survey.
- Andrea Nelson, my wife, for enduring the startup phase.

**This presentation can be downloaded from:**

[http://www.dynamicmeasurement.com/TAMU/170303\\_Lightning\\_Analysis\\_geoframeworks.pdf](http://www.dynamicmeasurement.com/TAMU/170303_Lightning_Analysis_geoframeworks.pdf)

**Or with the appendix from:**

[http://www.dynamicmeasurement.com/TAMU/170303\\_Lightning\\_Analysis\\_geoframeworks\\_for\\_Interns.pdf](http://www.dynamicmeasurement.com/TAMU/170303_Lightning_Analysis_geoframeworks_for_Interns.pdf)





# Thank You!



- H. Roice Nelson, Jr., Geophysicist  
cell: 713.542.2207  
e-mail: [roice@dynamicmeasurement.com](mailto:roice@dynamicmeasurement.com)  
[www.dynamicmeasurement.com](http://www.dynamicmeasurement.com)  
[www.dynamicmeasurement.com/TAMU](http://www.dynamicmeasurement.com/TAMU)  
[www.dynamicmeasurement.com/LI](http://www.dynamicmeasurement.com/LI)
- 211 Baker Road #382  
Barker, TX 77413  
– Office: 281.579.0172
- 2155 West 700 South #31  
Cedar City, UT 84720  
– Fax: 435.267.2668